



**COMMONWEALTH OF PENNSYLVANIA
DEPARTMENT OF ENVIRONMENTAL PROTECTION
AIR QUALITY PROGRAM**

TITLE V/STATE OPERATING PERMIT

Issue Date: January 29, 2020

Effective Date: February 1, 2020

Expiration Date: January 31, 2025

In accordance with the provisions of the Air Pollution Control Act, the Act of January 8, 1960, P.L. 2119, as amended, and 25 Pa. Code Chapter 127, the Owner, [and Operator if noted] (hereinafter referred to as permittee) identified below is authorized by the Department of Environmental Protection (Department) to operate the air emission source(s) more fully described in this permit. This Facility is subject to all terms and conditions specified in this permit. Nothing in this permit relieves the permittee from its obligations to comply with all applicable Federal, State and Local laws and regulations.

The regulatory or statutory authority for each permit condition is set forth in brackets. All terms and conditions in this permit are federally enforceable applicable requirements unless otherwise designated as "State-Only" or "non-applicable" requirements.

TITLE V Permit No: 36-05019

Federal Tax Id - Plant Code: 02-0510023-1

Owner Information

Name: ANVIL INTL LLC
Mailing Address: 1411 LANCASTER AVE
COLUMBIA, PA 17512-1939

Plant Information

Plant: ANVIL INTL/COLUMBIA FKA GRINNELL
Location: 36 Lancaster County 36002 Columbia Borough
SIC Code: 3322 Manufacturing - Malleable Iron Foundries

Responsible Official

Name: BOB KIM
Title: GENERAL MGR
Phone: (717) 684 - 4400

Permit Contact Person

Name: GREG K WISE
Title: EHS MGR
Phone: (717) 684 - 4400

[Signature] _____
WILLIAM R. WEAVER, SOUTH CENTRAL REGION AIR PROGRAM MANAGER



SECTION A. Table of Contents

Section A. Facility/Source Identification

Table of Contents
Site Inventory List

Section B. General Title V Requirements

- #001 Definitions
- #002 Prohibition of Air Pollution
- #003 Property Rights
- #004 Permit Expiration
- #005 Permit Renewal
- #006 Transfer of Ownership or Operational Control
- #007 Inspection and Entry
- #008 Compliance Requirements
- #009 Need to Halt or Reduce Activity Not a Defense
- #010 Duty to Provide Information
- #011 Reopening and Revising the Title V Permit for Cause
- #012 Reopening a Title V Permit for Cause by EPA
- #013 Operating Permit Application Review by the EPA
- #014 Significant Operating Permit Modifications
- #015 Minor Operating Permit Modifications
- #016 Administrative Operating Permit Amendments
- #017 Severability Clause
- #018 Fee Payment
- #019 Authorization for De Minimis Emission Increases
- #020 Reactivation of Sources
- #021 Circumvention
- #022 Submissions
- #023 Sampling, Testing and Monitoring Procedures
- #024 Recordkeeping Requirements
- #025 Reporting Requirements
- #026 Compliance Certification
- #027 Operational Flexibility
- #028 Risk Management
- #029 Approved Economic Incentives and Emission Trading Programs
- #030 Permit Shield
- #031 Malfunctions, Emergencies or Incidents of Excess Emissions
- #032 Reporting
- #033 Report Format

Section C. Site Level Title V Requirements

- C-I: Restrictions
- C-II: Testing Requirements
- C-III: Monitoring Requirements
- C-IV: Recordkeeping Requirements
- C-V: Reporting Requirements
- C-VI: Work Practice Standards
- C-VII: Additional Requirements
- C-VIII: Compliance Certification
- C-IX: Compliance Schedule

Section D. Source Level Title V Requirements

- D-I: Restrictions
- D-II: Testing Requirements
- D-III: Monitoring Requirements



SECTION A. Table of Contents

- D-IV: Recordkeeping Requirements
- D-V: Reporting Requirements
- D-VI: Work Practice Standards
- D-VII: Additional Requirements

Note: These same sub-sections are repeated for each source!

Section E. Source Group Restrictions

- E-I: Restrictions
- E-II: Testing Requirements
- E-III: Monitoring Requirements
- E-IV: Recordkeeping Requirements
- E-V: Reporting Requirements
- E-VI: Work Practice Standards
- E-VII: Additional Requirements

Section F. Alternative Operating Scenario(s)

- F-I: Restrictions
- F-II: Testing Requirements
- F-III: Monitoring Requirements
- F-IV: Recordkeeping Requirements
- F-V: Reporting Requirements
- F-VI: Work Practice Standards
- F-VII: Additional Requirements

Section G. Emission Restriction Summary

Section H. Miscellaneous

**SECTION A. Site Inventory List**

Source ID	Source Name	Capacity/Throughput		Fuel/Material
033	SUPERIOR/MOHAWK BOILER	2.900	MCF/HR	Natural Gas
036A	JOHNSTON BOILER	25.100	MCF/HR	Natural Gas
034	MISC. GAS USAGE	55.000	MCF/HR	Natural Gas
130	HOT DIP GALVANIZING #4 KETTLE	1.300	Tons/HR	CASTINGS
131	HOT DIP GALVANIZING #5 KETTLE	1.900	Tons/HR	CASTINGS
		3.000	MCF/HR	Natural Gas
187	SPRUE CRUSHER	50.000	Tons/HR	IRON
188	MELT OPERATIONS	44.000	Tons/HR	IRON
189	(2) SCRAP PREHEATERS	40.000	Tons/HR	IRON SCRAP
190	BURN OFF FURNACE	10.000	Lbs/HR	HANGERS
		0.700	MCF/HR	Natural Gas
191	SURFACE COATING DIP LINE	10.000	Lbs/HR	SOLVENT
196	WASHERS	50.000	Lbs/HR	SOLVENT
197	PARTS CLEANERS	20.000	Lbs/HR	SOLVENT
199	ANNEALING	9.500	Tons/HR	CASTINGS
200	SHELL CORE	2.000	Tons/HR	CORES
201	COREMAKING	3.000	Tons/HR	CORES
203	COLDBOX COREMAKING			
305	N.F. CLEANING	25.000	Tons/HR	CASTINGS
501	DISA POURING/CASTING	36.000	Tons/HR	IRON
502	DISA CASTING/COOLING	36.000	Tons/HR	CASTINGS
503	DISA CASTING/SHAKEOUT	36.000	Tons/HR	CASTINGS
504	DISA SAND SYSTEM	200.000	Tons/HR	SAND
505	GRINDING	27.000	Tons/HR	CASTINGS
506	DISA CASTING CLEANING	150.000	Tons/HR	IRON
601	SAVELLI POURING/CASTING	10.000	Tons/HR	IRON
602	SAVELLI CASTING/COOLING	10.000	Tons/HR	CASTINGS
603	SAVELLI CASTING/SHAKEOUT	10.000	Tons/HR	CASTINGS
C01A	WHEELABRATOR #428			
C02	WHEEL-FRYE #420			
C03C	WHEELABRATOR #427			
C04	FABRIC FILTER #425 (ETA OR EQUIVALENT)			
C06	FABRIC FILTER #426 (ETA OR EQUIVALENT)			
C07	FABRIC FILTER #414 (ETA OR EQUIVALENT)			
C08	DISA SAND SYSTEM - CYCLONIC SEPARATOR			
C10	WHEELABRATOR #441			
C101	DAKOTA SCRUBBER #454			
C11	WHEELABRATOR #442			
C12	WHEELABRATOR #430			
C13	WHEELABRATOR #DC-440			

**SECTION A. Site Inventory List**

Source ID	Source Name	Capacity/Throughput	Fuel/Material
C14	WHEELABRATOR #443		
C21	WHEELABRATOR #401		
C31	WHEELABRATOR #418		
C32	WHEELABRATOR #419		
C412A	WHEELABRATOR DC-412		
C451	WHEELABRATOR DC-451		
C89	WHEELABRATOR #410		
C90	THERMAL AFTERBURNER		
C91	WHEELABRATOR DC-446		
C92	WHEELABRATOR #DC-450		
FML001	NATURAL GAS		
S02	WHEELABRATOR #420		
S03	WHEELABRATOR #427		
S033	SUPERIOR/MOHAWK BOILER		
S04	DISA POURING CASTING/COOLING/CLEANING/SAND SYS/ & GRINDING		
S06	DISA POURING CASTING/COOLING/CLEANING/SAND SYS/ & GRINDING		
S07	N.F. CLEANING & GRINDING		
S10	DISA CASTING COOLING/SAND SYSTEM/GRINDING & SAVELLI SHAKEOUT		
S100	DISA CASTING SHAKEOUT/SPRUE CRUSHER/SAND SYSTEM		
S101A	COLDBOX COREMAKING		
S11	DISA POURING CASTING/SAND SYSTEM/ & SHAKEOUT		
S12	DISA CAST COOLING/SAND SYS/SPRUE CRUSHER/ & SAVELLI SHAKEOUT		
S13	DISA CASTING COOLING/SAND SYSTEM		
S201	COREMAKING		
S202	JOHNSTON BOILER		
S21	N.F. CLEANING		
S31	HD GALV KETTLE #4		
S32	GALV. KETTLE #5		
S40	SHELL CORE		
S405	WHEELABRATOR #428		
S41	SHELL CORE		
S412A	MELTING OPERATIONS		
S451	WHEELABRATOR DC-451		
S55	WASHERS		
S56	WASHERS		
S57	WASHERS		
S58	WASHERS		

**SECTION A. Site Inventory List**

Source ID	Source Name	Capacity/Throughput	Fuel/Material
S89	SCRAP PRE-HEATERS & SAVELLI CASTING/SHAKEOUT		
S90	BURN OFF FURNACE		
S92	GRINDING & SAVELLI CASTING/SHAKEOUT		
S98	ANNEALING		
Z02	POUR CASTING & CAST/COOLING/SAND SYSTEM		
Z04	CORE MAKING		
Z13	DISA/COOLING & SAND SYSTEM		
Z34	MISC. GAS USAGE		
Z35	ANNEALING		
Z88	MELTING OPERATIONS		
Z91	DIP LINE		
Z97	PARTS CLEANERS		

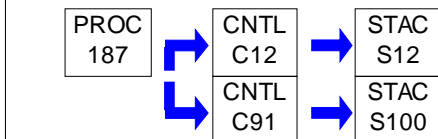
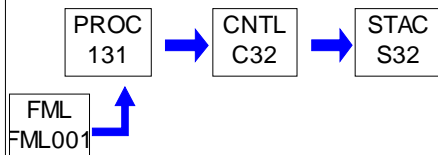
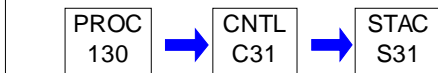
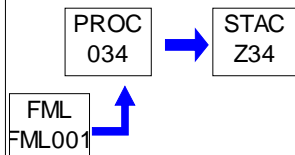
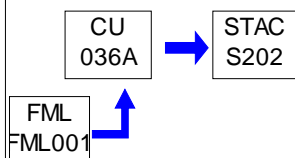
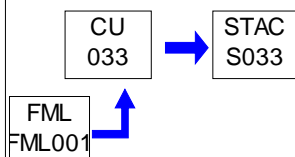
PERMIT MAPS



PERMIT MAPS

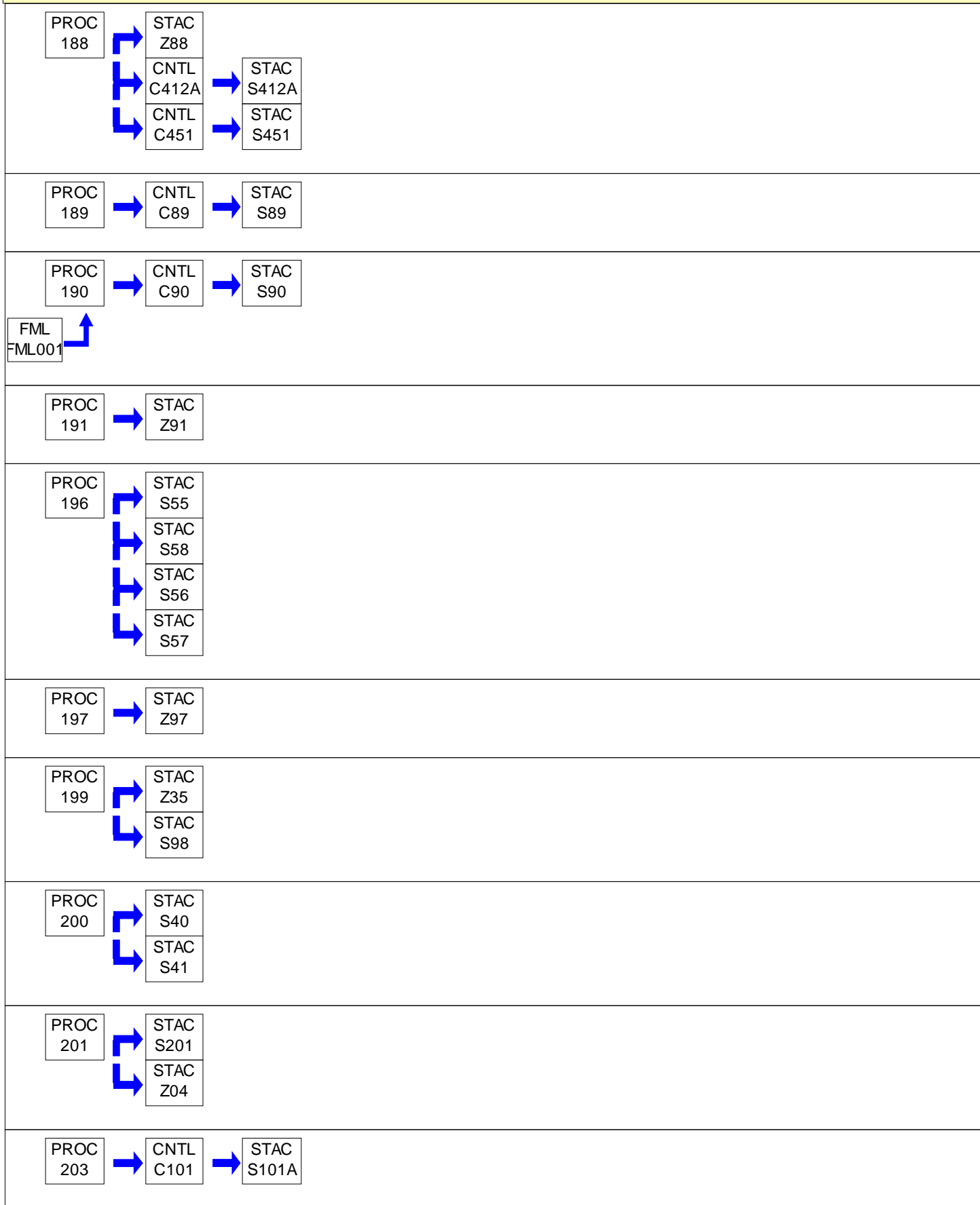



PERMIT MAPS

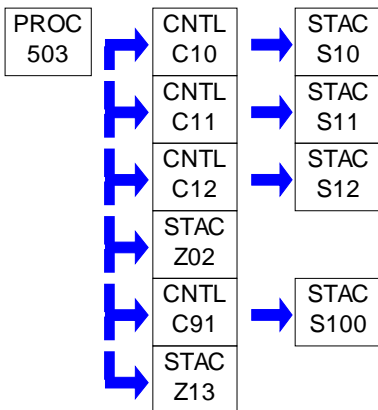
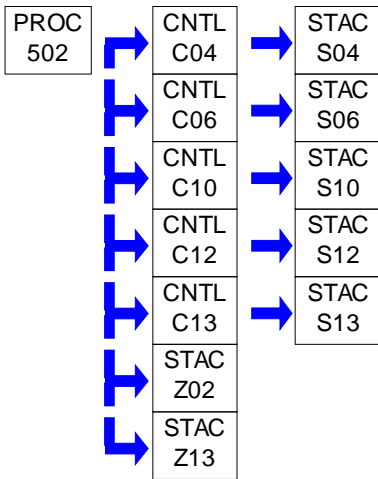
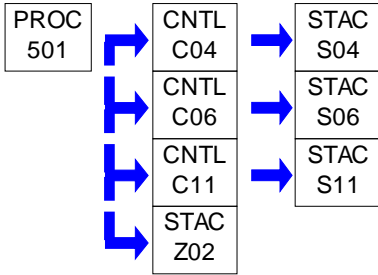
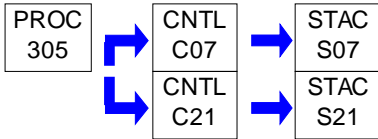



PERMIT MAPS

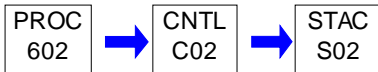
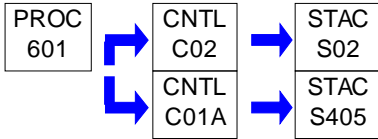
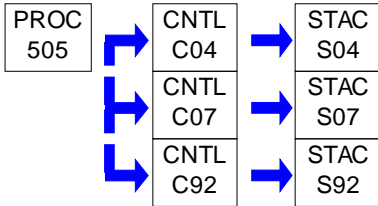
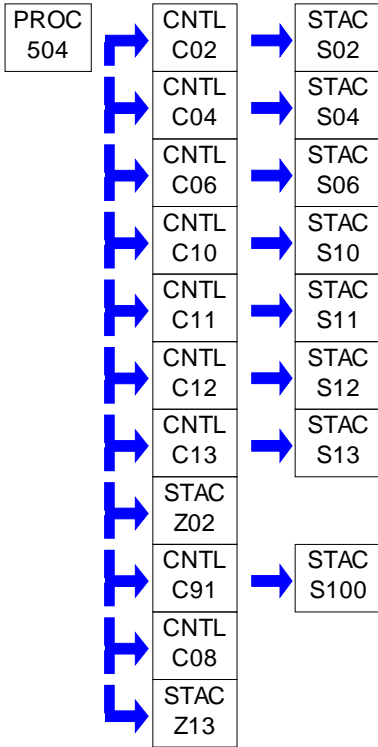



PERMIT MAPS

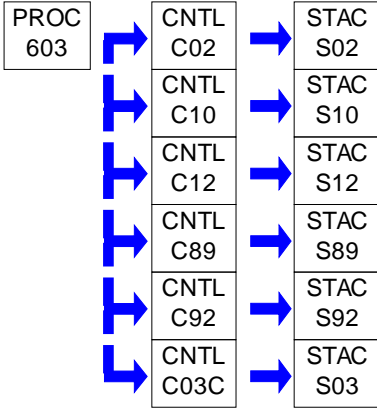

**SECTION B. General Title V Requirements****#001 [25 Pa. Code § 121.1]****Definitions**

Words and terms that are not otherwise defined in this permit shall have the meanings set forth in Section 3 of the Air Pollution Control Act (35 P.S. § 4003) and 25 Pa. Code § 121.1.

#002 [25 Pa. Code § 121.7]**Prohibition of Air Pollution**

No person may permit air pollution as that term is defined in the act.

#003 [25 Pa. Code § 127.512(c)(4)]**Property Rights**

This permit does not convey property rights of any sort, or any exclusive privileges.

#004 [25 Pa. Code § 127.446(a) and (c)]**Permit Expiration**

This operating permit is issued for a fixed term of five (5) years and shall expire on the date specified on Page 1 of this permit. The terms and conditions of the expired permit shall automatically continue pending issuance of a new Title V permit, provided the permittee has submitted a timely and complete application and paid applicable fees required under 25 Pa. Code Chapter 127, Subchapter I and the Department is unable, through no fault of the permittee, to issue or deny a new permit before the expiration of the previous permit. An application is complete if it contains sufficient information to begin processing the application, has the applicable sections completed and has been signed by a responsible official.

#005 [25 Pa. Code §§ 127.412, 127.413, 127.414, 127.446(e) & 127.503]**Permit Renewal**

(a) An application for the renewal of the Title V permit shall be submitted to the Department at least six (6) months, and not more than 18 months, before the expiration date of this permit. The renewal application is timely if a complete application is submitted to the Department's Regional Air Manager within the timeframe specified in this permit condition.

(b) The application for permit renewal shall include the current permit number, the appropriate permit renewal fee, a description of any permit revisions and off-permit changes that occurred during the permit term, and any applicable requirements that were promulgated and not incorporated into the permit during the permit term.

(c) The renewal application shall also include submission of proof that the local municipality and county, in which the facility is located, have been notified in accordance with 25 Pa. Code § 127.413. The application for renewal of the Title V permit shall also include submission of compliance review forms which have been used by the permittee to update information submitted in accordance with either 25 Pa. Code § 127.412(b) or § 127.412(j).

(d) The permittee, upon becoming aware that any relevant facts were omitted or incorrect information was submitted in the permit application, shall promptly submit such supplementary facts or corrected information during the permit renewal process. The permittee shall also promptly provide additional information as necessary to address any requirements that become applicable to the source after the date a complete renewal application was submitted but prior to release of a draft permit.

#006 [25 Pa. Code §§ 127.450(a)(4) & 127.464(a)]**Transfer of Ownership or Operational Control**

(a) In accordance with 25 Pa. Code § 127.450(a)(4), a change in ownership or operational control of the source shall be treated as an administrative amendment if:

(1) The Department determines that no other change in the permit is necessary;

(2) A written agreement has been submitted to the Department identifying the specific date of the transfer of permit responsibility, coverage and liability between the current and the new permittee; and,

(3) A compliance review form has been submitted to the Department and the permit transfer has been approved by the Department.

**SECTION B. General Title V Requirements**

(b) In accordance with 25 Pa. Code § 127.464(a), this permit may not be transferred to another person except in cases of transfer-of-ownership which are documented and approved to the satisfaction of the Department.

#007 [25 Pa. Code § 127.513, 35 P.S. § 4008 and § 114 of the CAA]**Inspection and Entry**

(a) Upon presentation of credentials and other documents as may be required by law for inspection and entry purposes, the permittee shall allow the Department of Environmental Protection or authorized representatives of the Department to perform the following:

- (1) Enter at reasonable times upon the permittee's premises where a Title V source is located or emissions related activity is conducted, or where records are kept under the conditions of this permit;
- (2) Have access to and copy or remove, at reasonable times, records that are kept under the conditions of this permit;
- (3) Inspect at reasonable times, facilities, equipment including monitoring and air pollution control equipment, practices, or operations regulated or required under this permit;
- (4) Sample or monitor, at reasonable times, substances or parameters, for the purpose of assuring compliance with the permit or applicable requirements as authorized by the Clean Air Act, the Air Pollution Control Act, or the regulations promulgated under the Acts.

(b) Pursuant to 35 P.S. § 4008, no person shall hinder, obstruct, prevent or interfere with the Department or its personnel in the performance of any duty authorized under the Air Pollution Control Act.

(c) Nothing in this permit condition shall limit the ability of the EPA to inspect or enter the premises of the permittee in accordance with Section 114 or other applicable provisions of the Clean Air Act.

#008 [25 Pa. Code §§ 127.25, 127.444, & 127.512(c)(1)]**Compliance Requirements**

(a) The permittee shall comply with the conditions of this permit. Noncompliance with this permit constitutes a violation of the Clean Air Act and the Air Pollution Control Act and is grounds for one (1) or more of the following:

- (1) Enforcement action
- (2) Permit termination, revocation and reissuance or modification
- (3) Denial of a permit renewal application

(b) A person may not cause or permit the operation of a source, which is subject to 25 Pa. Code Article III, unless the source(s) and air cleaning devices identified in the application for the plan approval and operating permit and the plan approval issued to the source are operated and maintained in accordance with specifications in the applications and the conditions in the plan approval and operating permit issued by the Department. A person may not cause or permit the operation of an air contamination source subject to 25 Pa. Code Chapter 127 in a manner inconsistent with good operating practices.

(c) For purposes of Sub-condition (b) of this permit condition, the specifications in applications for plan approvals and operating permits are the physical configurations and engineering design details which the Department determines are essential for the permittee's compliance with the applicable requirements in this Title V permit.

#009 [25 Pa. Code § 127.512(c)(2)]**Need to Halt or Reduce Activity Not a Defense**

It shall not be a defense for a permittee in an enforcement action that it would have been necessary to halt or reduce the permitted activity in order to maintain compliance with the conditions of this permit.

#010 [25 Pa. Code §§ 127.411(d) & 127.512(c)(5)]**Duty to Provide Information**

(a) The permittee shall furnish to the Department, within a reasonable time, information that the Department may request in writing to determine whether cause exists for modifying, revoking and reissuing, or terminating the permit, or

**SECTION B. General Title V Requirements**

to determine compliance with the permit.

(b) Upon request, the permittee shall also furnish to the Department copies of records that the permittee is required to keep by this permit, or for information claimed to be confidential, the permittee may furnish such records directly to the Administrator of EPA along with a claim of confidentiality.

#011 [25 Pa. Code §§ 127.463, 127.512(c)(3) & 127.542]**Reopening and Revising the Title V Permit for Cause**

(a) This Title V permit may be modified, revoked, reopened and reissued or terminated for cause. The filing of a request by the permittee for a permit modification, revocation and reissuance, or termination, or of a notification of planned changes or anticipated noncompliance does not stay a permit condition.

(b) This permit may be reopened, revised and reissued prior to expiration of the permit under one or more of the following circumstances:

(1) Additional applicable requirements under the Clean Air Act or the Air Pollution Control Act become applicable to a Title V facility with a remaining permit term of three (3) or more years prior to the expiration date of this permit. The Department will revise the permit as expeditiously as practicable but not later than 18 months after promulgation of the applicable standards or regulations. No such revision is required if the effective date of the requirement is later than the expiration date of this permit, unless the original permit or its terms and conditions has been extended.

(2) Additional requirements, including excess emissions requirements, become applicable to an affected source under the acid rain program. Upon approval by the Administrator of EPA, excess emissions offset plans for an affected source shall be incorporated into the permit.

(3) The Department or the EPA determines that this permit contains a material mistake or inaccurate statements were made in establishing the emissions standards or other terms or conditions of this permit.

(4) The Department or the Administrator of EPA determines that the permit must be revised or revoked to assure compliance with the applicable requirements.

(c) Proceedings to revise this permit shall follow the same procedures which apply to initial permit issuance and shall affect only those parts of this permit for which cause to revise exists. The revision shall be made as expeditiously as practicable.

(d) Regardless of whether a revision is made in accordance with (b)(1) above, the permittee shall meet the applicable standards or regulations promulgated under the Clean Air Act within the time frame required by standards or regulations.

#012 [25 Pa. Code § 127.543]**Reopening a Title V Permit for Cause by EPA**

As required by the Clean Air Act and regulations adopted thereunder, this permit may be modified, reopened and reissued, revoked or terminated for cause by EPA in accordance with procedures specified in 25 Pa. Code § 127.543.

#013 [25 Pa. Code § 127.522(a)]**Operating Permit Application Review by the EPA**

The applicant may be required by the Department to provide a copy of the permit application, including the compliance plan, directly to the Administrator of the EPA. Copies of title V permit applications to EPA, pursuant to 25 PA Code §127.522(a), shall be submitted, if required, to the following EPA e-mail box:

R3_Air_Apps_and_Notices@epa.gov

Please place the following in the subject line: TV [permit number], [Facility Name].

#014 [25 Pa. Code § 127.541]**Significant Operating Permit Modifications**

When permit modifications during the term of this permit do not qualify as minor permit modifications or administrative amendments, the permittee shall submit an application for significant Title V permit modifications in accordance with

**SECTION B. General Title V Requirements**

25 Pa. Code § 127.541. Notifications to EPA, pursuant to 25 PA Code §127.522(a), if required, shall be submitted, to the following EPA e-mail box:

R3_Air_Apps_and_Notices@epa.gov

Please place the following in the subject line: TV [permit number], [Facility Name].

#015 [25 Pa. Code §§ 121.1 & 127.462]**Minor Operating Permit Modifications**

The permittee may make minor operating permit modifications (as defined in 25 Pa. Code §121.1), on an expedited basis, in accordance with 25 Pa. Code §127.462 (relating to minor operating permit modifications). Notifications to EPA, pursuant to 25 PA Code §127.462(c), if required, shall be submitted, to the following EPA e-mail box:

R3_Air_Apps_and_Notices@epa.gov

Please place the following in the subject line: TV [permit number], [Facility Name].

#016 [25 Pa. Code § 127.450]**Administrative Operating Permit Amendments**

(a) The permittee may request administrative operating permit amendments, as defined in 25 Pa. Code §127.450(a). Copies of request for administrative permit amendment to EPA, pursuant to 25 PA Code §127.450(c)(1), if required, shall be submitted to the following EPA e-mail box:

R3_Air_Apps_and_Notices@epa.gov

Please place the following in the subject line: TV [permit number], [Facility Name].

(b) Upon final action by the Department granting a request for an administrative operating permit amendment covered under §127.450(a)(5), the permit shield provisions in 25 Pa. Code § 127.516 (relating to permit shield) shall apply to administrative permit amendments incorporated in this Title V Permit in accordance with §127.450(c), unless precluded by the Clean Air Act or the regulations thereunder.

#017 [25 Pa. Code § 127.512(b)]**Severability Clause**

The provisions of this permit are severable, and if any provision of this permit is determined by the Environmental Hearing Board or a court of competent jurisdiction, or US EPA to be invalid or unenforceable, such a determination will not affect the remaining provisions of this permit.

#018 [25 Pa. Code §§ 127.704, 127.705 & 127.707]**Fee Payment**

(a) The permittee shall pay fees to the Department in accordance with the applicable fee schedules in 25 Pa. Code Chapter 127, Subchapter I (relating to plan approval and operating permit fees).

(b) Emission Fees. The permittee shall, on or before September 1st of each year, pay applicable annual Title V emission fees for emissions occurring in the previous calendar year as specified in 25 Pa. Code § 127.705. The permittee is not required to pay an emission fee for emissions of more than 4,000 tons of each regulated pollutant emitted from the facility.

(c) As used in this permit condition, the term "regulated pollutant" is defined as a VOC, each pollutant regulated under Sections 111 and 112 of the Clean Air Act and each pollutant for which a National Ambient Air Quality Standard has been promulgated, except that carbon monoxide is excluded.

(d) Late Payment. Late payment of emission fees will subject the permittee to the penalties prescribed in 25 Pa. Code § 127.707 and may result in the suspension or termination of the Title V permit. The permittee shall pay a penalty of fifty percent (50%) of the fee amount, plus interest on the fee amount computed in accordance with 26 U.S.C.A. § 6621(a)(2) from the date the emission fee should have been paid in accordance with the time frame specified in 25 Pa. Code § 127.705(c).

**SECTION B. General Title V Requirements**

(e) The permittee shall pay an annual operating permit administration fee according to the fee schedule established in 25 Pa. Code § 127.704(c) if the facility, identified in Subparagraph (iv) of the definition of the term "Title V facility" in 25 Pa. Code § 121.1, is subject to Title V after the EPA Administrator completes a rulemaking requiring regulation of those sources under Title V of the Clean Air Act.

(f) This permit condition does not apply to a Title V facility which qualifies for exemption from emission fees under 35 P.S. § 4006.3(f).

#019 [25 Pa. Code §§ 127.14(b) & 127.449]**Authorization for De Minimis Emission Increases**

(a) This permit authorizes de minimis emission increases from a new or existing source in accordance with 25 Pa. Code §§ 127.14 and 127.449 without the need for a plan approval or prior issuance of a permit modification. The permittee shall provide the Department with seven (7) days prior written notice before commencing any de minimis emissions increase that would result from either: (1) a physical change of minor significance under § 127.14(c)(1); or (2) the construction, installation, modification or reactivation of an air contamination source. The written notice shall:

- (1) Identify and describe the pollutants that will be emitted as a result of the de minimis emissions increase.
- (2) Provide emission rates expressed in tons per year and in terms necessary to establish compliance consistent with any applicable requirement.

The Department may disapprove or condition de minimis emission increases at any time.

(b) Except as provided below in (c) and (d) of this permit condition, the permittee is authorized during the term of this permit to make de minimis emission increases (expressed in tons per year) up to the following amounts without the need for a plan approval or prior issuance of a permit modification:

- (1) Four tons of carbon monoxide from a single source during the term of the permit and 20 tons of carbon monoxide at the facility during the term of the permit.
- (2) One ton of NO_x from a single source during the term of the permit and 5 tons of NO_x at the facility during the term of the permit.
- (3) One and six-tenths tons of the oxides of sulfur from a single source during the term of the permit and 8.0 tons of oxides of sulfur at the facility during the term of the permit.
- (4) Six-tenths of a ton of PM₁₀ from a single source during the term of the permit and 3.0 tons of PM₁₀ at the facility during the term of the permit. This shall include emissions of a pollutant regulated under Section 112 of the Clean Air Act unless precluded by the Clean Air Act or 25 Pa. Code Article III.
- (5) One ton of VOCs from a single source during the term of the permit and 5.0 tons of VOCs at the facility during the term of the permit. This shall include emissions of a pollutant regulated under Section 112 of the Clean Air Act unless precluded by the Clean Air Act or 25 Pa. Code Article III.

(c) In accordance with § 127.14, the permittee may install the following minor sources without the need for a plan approval:

- (1) Air conditioning or ventilation systems not designed to remove pollutants generated or released from other sources.
- (2) Combustion units rated at 2,500,000 or less Btu per hour of heat input.
- (3) Combustion units with a rated capacity of less than 10,000,000 Btu per hour heat input fueled by natural gas supplied by a public utility, liquefied petroleum gas or by commercial fuel oils which are No. 2 or lighter, viscosity less than or equal to 5.82 c St, and which meet the sulfur content requirements of 25 Pa. Code § 123.22 (relating to combustion units). For purposes of this permit, commercial fuel oil shall be virgin oil which has no reprocessed, recycled or waste material added.
- (4) Space heaters which heat by direct heat transfer.

**SECTION B. General Title V Requirements**

(5) Laboratory equipment used exclusively for chemical or physical analysis.

(6) Other sources and classes of sources determined to be of minor significance by the Department.

(d) This permit does not authorize de minimis emission increases if the emissions increase would cause one or more of the following:

(1) Increase the emissions of a pollutant regulated under Section 112 of the Clean Air Act except as authorized in Subparagraphs (b)(4) and (5) of this permit condition.

(2) Subject the facility to the prevention of significant deterioration requirements in 25 Pa. Code Chapter 127, Subchapter D and/or the new source review requirements in Subchapter E.

(3) Violate any applicable requirement of the Air Pollution Control Act, the Clean Air Act, or the regulations promulgated under either of the acts.

(4) Changes which are modifications under any provision of Title I of the Clean Air Act and emission increases which would exceed the allowable emissions level (expressed as a rate of emissions or in terms of total emissions) under the Title V permit.

(e) Unless precluded by the Clean Air Act or the regulations thereunder, the permit shield described in 25 Pa. Code § 127.516 (relating to permit shield) shall extend to the changes made under 25 Pa. Code § 127.449 (relating to de minimis emission increases).

(f) Emissions authorized under this permit condition shall be included in the monitoring, recordkeeping and reporting requirements of this permit.

(g) Except for de minimis emission increases allowed under this permit, 25 Pa. Code § 127.449, or sources and physical changes meeting the requirements of 25 Pa. Code § 127.14, the permittee is prohibited from making physical changes or engaging in activities that are not specifically authorized under this permit without first applying for a plan approval. In accordance with § 127.14(b), a plan approval is not required for the construction, modification, reactivation, or installation of the sources creating the de minimis emissions increase.

(h) The permittee may not meet de minimis emission threshold levels by offsetting emission increases or decreases at the same source.

#020 [25 Pa. Code §§ 127.11a & 127.215]**Reactivation of Sources**

(a) The permittee may reactivate a source at the facility that has been out of operation or production for at least one year, but less than or equal to five (5) years, if the source is reactivated in accordance with the requirements of 25 Pa. Code §§ 127.11a and 127.215. The reactivated source will not be considered a new source.

(b) A source which has been out of operation or production for more than five (5) years but less than 10 years may be reactivated and will not be considered a new source if the permittee satisfies the conditions specified in 25 Pa. Code § 127.11a(b).

#021 [25 Pa. Code §§ 121.9 & 127.216]**Circumvention**

(a) The owner of this Title V facility, or any other person, may not circumvent the new source review requirements of 25 Pa. Code Chapter 127, Subchapter E by causing or allowing a pattern of ownership or development, including the phasing, staging, delaying or engaging in incremental construction, over a geographic area of a facility which, except for the pattern of ownership or development, would otherwise require a permit or submission of a plan approval application.

(b) No person may permit the use of a device, stack height which exceeds good engineering practice stack height, dispersion technique or other technique which, without resulting in reduction of the total amount of air contaminants emitted, conceals or dilutes an emission of air contaminants which would otherwise be in violation of this permit, the Air Pollution Control Act or the regulations promulgated thereunder, except that with prior approval of the Department,

**SECTION B. General Title V Requirements**

the device or technique may be used for control of malodors.

#022 [25 Pa. Code §§ 127.402(d) & 127.513(1)]**Submissions**

(a) Reports, test data, monitoring data, notifications and requests for renewal of the permit shall be submitted to the:

Regional Air Program Manager
PA Department of Environmental Protection
(At the address given on the permit transmittal letter,
or otherwise notified)

(b) Any report or notification for the EPA Administrator or EPA Region III should be addressed to:

Office of Air Enforcement and Compliance Assistance (3AP20)
United States Environmental Protection Agency
Region 3
1650 Arch Street
Philadelphia, PA 19103-2029

(c) An application, form, report or compliance certification submitted pursuant to this permit condition shall contain certification by a responsible official as to truth, accuracy, and completeness as required under 25 Pa. Code § 127.402(d). Unless otherwise required by the Clean Air Act or regulations adopted thereunder, this certification and any other certification required pursuant to this permit shall state that, based on information and belief formed after reasonable inquiry, the statements and information in the document are true, accurate and complete.

#023 [25 Pa. Code §§ 127.441(c) & 127.463(e); Chapter 139; & 114(a)(3), 504(b) of the CAA]**Sampling, Testing and Monitoring Procedures**

(a) The permittee shall perform the emissions monitoring and analysis procedures or test methods for applicable requirements of this Title V permit. In addition to the sampling, testing and monitoring procedures specified in this permit, the Permittee shall comply with any additional applicable requirements promulgated under the Clean Air Act after permit issuance regardless of whether the permit is revised.

(b) The sampling, testing and monitoring required under the applicable requirements of this permit, shall be conducted in accordance with the requirements of 25 Pa. Code Chapter 139 unless alternative methodology is required by the Clean Air Act (including §§ 114(a)(3) and 504(b)) and regulations adopted thereunder.

#024 [25 Pa. Code §§ 127.511 & Chapter 135]**Recordkeeping Requirements**

(a) The permittee shall maintain and make available, upon request by the Department, records of required monitoring information that include the following:

- (1) The date, place (as defined in the permit) and time of sampling or measurements.
- (2) The dates the analyses were performed.
- (3) The company or entity that performed the analyses.
- (4) The analytical techniques or methods used.
- (5) The results of the analyses.
- (6) The operating conditions as existing at the time of sampling or measurement.

(b) The permittee shall retain records of the required monitoring data and supporting information for at least five (5) years from the date of the monitoring sample, measurement, report or application. Supporting information includes the calibration data and maintenance records and original strip-chart recordings for continuous monitoring instrumentation, and copies of reports required by the permit.

**SECTION B. General Title V Requirements**

(c) The permittee shall maintain and make available to the Department upon request, records including computerized records that may be necessary to comply with the reporting, recordkeeping and emission statement requirements in 25 Pa. Code Chapter 135 (relating to reporting of sources). In accordance with 25 Pa. Code Chapter 135, § 135.5, such records may include records of production, fuel usage, maintenance of production or pollution control equipment or other information determined by the Department to be necessary for identification and quantification of potential and actual air contaminant emissions. If direct recordkeeping is not possible or practical, sufficient records shall be kept to provide the needed information by indirect means.

#025 [25 Pa. Code §§ 127.411(d), 127.442, 127.463(e) & 127.511(c)]**Reporting Requirements**

(a) The permittee shall comply with the reporting requirements for the applicable requirements specified in this Title V permit. In addition to the reporting requirements specified herein, the permittee shall comply with any additional applicable reporting requirements promulgated under the Clean Air Act after permit issuance regardless of whether the permit is revised.

(b) Pursuant to 25 Pa. Code § 127.511(c), the permittee shall submit reports of required monitoring at least every six (6) months unless otherwise specified in this permit. Instances of deviations (as defined in 25 Pa. Code § 121.1) from permit requirements shall be clearly identified in the reports. The reporting of deviations shall include the probable cause of the deviations and corrective actions or preventative measures taken, except that sources with continuous emission monitoring systems shall report according to the protocol established and approved by the Department for the source. The required reports shall be certified by a responsible official.

(c) Every report submitted to the Department under this permit condition shall comply with the submission procedures specified in Section B, Condition #022(c) of this permit.

(d) Any records, reports or information obtained by the Department or referred to in a public hearing shall be made available to the public by the Department except for such records, reports or information for which the permittee has shown cause that the documents should be considered confidential and protected from disclosure to the public under Section 4013.2 of the Air Pollution Control Act and consistent with Sections 112(d) and 114(c) of the Clean Air Act and 25 Pa. Code § 127.411(d). The permittee may not request a claim of confidentiality for any emissions data generated for the Title V facility.

#026 [25 Pa. Code § 127.513]**Compliance Certification**

(a) One year after the date of issuance of the Title V permit, and each year thereafter, unless specified elsewhere in the permit, the permittee shall submit to the Department and EPA Region III a certificate of compliance with the terms and conditions in this permit, for the previous year, including the emission limitations, standards or work practices. This certification shall include:

- (1) The identification of each term or condition of the permit that is the basis of the certification.
- (2) The compliance status.
- (3) The methods used for determining the compliance status of the source, currently and over the reporting period.
- (4) Whether compliance was continuous or intermittent.

(b) The compliance certification shall be postmarked or hand-delivered no later than thirty days after each anniversary of the date of issuance of this Title V Operating Permit, or on the submittal date specified elsewhere in the permit, to the Department and EPA in accordance with the submission requirements specified in condition #022 of this section.

#027 [25 Pa. Code § 127.3]**Operational Flexibility**

The permittee is authorized to make changes within the Title V facility in accordance with the following provisions in 25 Pa. Code Chapter 127 which implement the operational flexibility requirements of Section 502(b)(10) of the Clean Air Act and Section 6.1(i) of the Air Pollution Control Act:

- (1) Section 127.14 (relating to exemptions)

**SECTION B. General Title V Requirements**

- (2) Section 127.447 (relating to alternative operating scenarios)
- (3) Section 127.448 (relating to emissions trading at facilities with federally enforceable emissions caps)
- (4) Section 127.449 (relating to de minimis emission increases)
- (5) Section 127.450 (relating to administrative operating permit amendments)
- (6) Section 127.462 (relating to minor operating permit amendments)
- (7) Subchapter H (relating to general plan approvals and operating permits)

#028 [25 Pa. Code §§ 127.441(d), 127.512(i) and 40 CFR Part 68]**Risk Management**

(a) If required by Section 112(r) of the Clean Air Act, the permittee shall develop and implement an accidental release program consistent with requirements of the Clean Air Act, 40 CFR Part 68 (relating to chemical accident prevention provisions) and the Federal Chemical Safety Information, Site Security and Fuels Regulatory Relief Act (P.L. 106-40).

(b) The permittee shall prepare and implement a Risk Management Plan (RMP) which meets the requirements of Section 112(r) of the Clean Air Act, 40 CFR Part 68 and the Federal Chemical Safety Information, Site Security and Fuels Regulatory Relief Act when a regulated substance listed in 40 CFR § 68.130 is present in a process in more than the listed threshold quantity at the Title V facility. The permittee shall submit the RMP to the federal Environmental Protection Agency according to the following schedule and requirements:

(1) The permittee shall submit the first RMP to a central point specified by EPA no later than the latest of the following:

- (i) Three years after the date on which a regulated substance is first listed under § 68.130; or,
- (ii) The date on which a regulated substance is first present above a threshold quantity in a process.

(2) The permittee shall submit any additional relevant information requested by the Department or EPA concerning the RMP and shall make subsequent submissions of RMPs in accordance with 40 CFR § 68.190.

(3) The permittee shall certify that the RMP is accurate and complete in accordance with the requirements of 40 CFR Part 68, including a checklist addressing the required elements of a complete RMP.

(c) As used in this permit condition, the term "process" shall be as defined in 40 CFR § 68.3. The term "process" means any activity involving a regulated substance including any use, storage, manufacturing, handling, or on-site movement of such substances or any combination of these activities. For purposes of this definition, any group of vessels that are interconnected, or separate vessels that are located such that a regulated substance could be involved in a potential release, shall be considered a single process.

(d) If the Title V facility is subject to 40 CFR Part 68, as part of the certification required under this permit, the permittee shall:

(1) Submit a compliance schedule for satisfying the requirements of 40 CFR Part 68 by the date specified in 40 CFR § 68.10(a); or,

(2) Certify that the Title V facility is in compliance with all requirements of 40 CFR Part 68 including the registration and submission of the RMP.

(e) If the Title V facility is subject to 40 CFR Part 68, the permittee shall maintain records supporting the implementation of an accidental release program for five (5) years in accordance with 40 CFR § 68.200.

(f) When the Title V facility is subject to the accidental release program requirements of Section 112(r) of the Clean Air Act and 40 CFR Part 68, appropriate enforcement action will be taken by the Department if:

- (1) The permittee fails to register and submit the RMP or a revised plan pursuant to 40 CFR Part 68.

**SECTION B. General Title V Requirements**

(2) The permittee fails to submit a compliance schedule or include a statement in the compliance certification required under Condition #26 of Section B of this Title V permit that the Title V facility is in compliance with the requirements of Section 112(r) of the Clean Air Act, 40 CFR Part 68, and 25 Pa. Code § 127.512(i).

#029 [25 Pa. Code § 127.512(e)]**Approved Economic Incentives and Emission Trading Programs**

No permit revision shall be required under approved economic incentives, marketable permits, emissions trading and other similar programs or processes for changes that are provided for in this Title V permit.

#030 [25 Pa. Code §§ 127.516, 127.450(d), 127.449(f) & 127.462(g)]**Permit Shield**

(a) The permittee's compliance with the conditions of this permit shall be deemed in compliance with applicable requirements (as defined in 25 Pa. Code § 121.1) as of the date of permit issuance if either of the following applies:

- (1) The applicable requirements are included and are specifically identified in this permit.
- (2) The Department specifically identifies in the permit other requirements that are not applicable to the permitted facility or source.

(b) Nothing in 25 Pa. Code § 127.516 or the Title V permit shall alter or affect the following:

- (1) The provisions of Section 303 of the Clean Air Act, including the authority of the Administrator of the EPA provided thereunder.
- (2) The liability of the permittee for a violation of an applicable requirement prior to the time of permit issuance.
- (3) The applicable requirements of the acid rain program, consistent with Section 408(a) of the Clean Air Act.
- (4) The ability of the EPA to obtain information from the permittee under Section 114 of the Clean Air Act.

(c) Unless precluded by the Clean Air Act or regulations thereunder, final action by the Department incorporating a significant permit modification in this Title V Permit shall be covered by the permit shield at the time that the permit containing the significant modification is issued.

#031 [25 Pa. Code § 127.442]**Malfunctions, Emergencies or Incidents of Excess Emissions**

(a) The permittee shall report malfunctions, emergencies or incidents of excess emissions to the Department. A malfunction is any sudden, infrequent, and not reasonably preventable failure of air pollution control equipment, process equipment, or a process to operate in a normal or usual manner. An emergency is any situation arising from sudden and reasonably unforeseeable events beyond the control of the owner or operator of a facility which requires immediate corrective action to restore normal operation and which causes the emission source to exceed emissions, due to unavoidable increases in emissions attributable to the situation. An emergency shall not include situations caused by improperly designed equipment, lack of preventive maintenance, careless or improper operation, or operator error.

(b) When the malfunction, emergency or incident of excess emissions poses an imminent danger to the public health, safety, welfare, or environment, it shall be reported to the Department and the County Emergency Management Agency by telephone within one (1) hour after the discovery of the malfunction, emergency or incident of excess emissions. The owner or operator shall submit a written or emailed report of instances of such malfunctions, emergencies or incidents of excess emissions to the Department within three (3) business days of the telephone report.

(c) The report shall describe the following:

1. name, permit or authorization number, and location of the facility,
2. nature and cause of the malfunction, emergency or incident,
3. date and time when the malfunction, emergency or incident was first observed,
4. expected duration of excess emissions,
5. estimated rate of emissions,
6. corrective actions or preventative measures taken.



SECTION B. General Title V Requirements

(d) Any malfunction, emergency or incident of excess emissions that is not subject to the notice requirements of paragraph (b) of this condition shall be reported to the Department by telephone within 24 hours (or by 4:00 PM of the next business day, whichever is later) of discovery and in writing or by e-mail within five (5) business days of discovery. The report shall contain the same information required by paragraph (c), and any permit specific malfunction reporting requirements.

(e) During an emergency an owner or operator may continue to operate the source at their discretion provided they submit justification for continued operation of a source during the emergency and follow all the notification and reporting requirements in accordance with paragraphs (b)-(d), as applicable, including any permit specific malfunction reporting requirements.

(f) Reports regarding malfunctions, emergencies or incidents of excess emissions shall be submitted to the appropriate DEP Regional Office Air Program Manager.

(g) Any emissions resulted from malfunction or emergency are to be reported in the annual emissions inventory report, if the annual emissions inventory report is required by permit or authorization.

#032 [25 Pa. Code §135.3]

Reporting

(a) The permittee shall submit by March 1 of each year an annual emissions report for the preceding calendar year. The report shall include information for all active previously reported sources, new sources which were first operated during the preceding calendar year, and sources modified during the same period which were not previously reported. All air emissions from the facility should be estimated and reported.

(b) A source owner or operator may request an extension of time from the Department for the filing of an annual emissions report, and the Department may grant the extension for reasonable cause.

#033 [25 Pa. Code §135.4]

Report Format

Emissions reports shall contain sufficient information to enable the Department to complete its emission inventory. Emissions reports shall be made by the source owner or operator in a format specified by the Department.

**SECTION C. Site Level Requirements****I. RESTRICTIONS.****Emission Restriction(s).****# 001 [25 Pa. Code §123.1]****Prohibition of certain fugitive emissions**

(a) No person shall permit the emission into the outdoor atmosphere of a fugitive air contaminant from a source other than the following:

- (1) Construction or demolition of buildings or structures.
- (2) Grading, paving and maintenance of roads and streets.
- (3) Use of roads and streets. Emissions from material in or on trucks, railroad cars and other vehicular equipment are not considered as emissions from use of roads and streets.
- (4) Clearing of land.
- (5) Stockpiling of materials.
- (6) Open burning operations.
- (7) Sources and classes of sources other than those identified above, for which the operator has obtained a determination from the Department that fugitive emissions from the source, after appropriate control, meet the following requirements:
 - (i) the emissions are of minor significance with respect to causing air pollution; and
 - (ii) the emissions are not preventing or interfering with the attainment or maintenance of any ambient air quality standard.

002 [25 Pa. Code §123.2]**Fugitive particulate matter**

No person shall permit fugitive particulate matter to be emitted into the outdoor atmosphere from a source specified in Section C, Condition #001 if such emissions are visible at the point the emissions pass outside the person's property.

003 [25 Pa. Code §123.31]**Limitations**

No person shall permit the emission into the outdoor atmosphere of any malodorous air contaminants from any source in such a manner that the malodors are detectable outside the property of the person on whose land the source is being operated.

004 [25 Pa. Code §123.41]**Limitations**

No person shall permit the emission into the outdoor atmosphere of visible air contaminants in such a manner that the opacity of the emission is either of the following:

- (1) Equal to or greater than 20% for a period or periods aggregating more than three minutes in any 1 hour.
- (2) Equal to or greater than 60% at any time.

**SECTION C. Site Level Requirements****# 005 [25 Pa. Code §123.42]****Exceptions**

The limitations of 123.41 (relating to limitations) shall not apply to a visible emission in any of the following instances:

- (1) when the presence of uncombined water is the only reason for failure of the emission to meet the limitations.
- (2) When the emission results from the operation of equipment used solely to train and test persons in observing the opacity of visible emissions.
- (3) When the emission results from sources specified in 123.1(a)(1) -- (7) (relating to prohibition of certain fugitive emissions).

006 [25 Pa. Code §127.441]**Operating permit terms and conditions.**

- (a) The permittee shall limit the annual plant-wide melt rate to 245,280 tons of metal, based on a consecutive 12-month rolling total.
- (b) The permittee shall limit HAP emissions to less than 10 tpy for each individual HAP and less than 25 tpy for a combination of all HAPs, based on a consecutive 12-month rolling total.

II. TESTING REQUIREMENTS.**# 007 [25 Pa. Code §127.511]****Monitoring and related recordkeeping and reporting requirements.**

The Department reserves the right to require exhaust stack testing of the sources by the permittee as necessary during the permit term to verify emissions for purposes including emission fees, malfunctions or permit condition violations.

008 [25 Pa. Code §139.1]**Sampling facilities.**

Upon the request of the Department, the person responsible for a source shall provide adequate sampling ports, safe sampling platforms and adequate utilities for the performance by the Department of tests on such source. The Department will set forth, in the request, the time period in which the facilities shall be provided as well as the specifications for such facilities.

III. MONITORING REQUIREMENTS.**# 009 [25 Pa. Code §123.43]****Measuring techniques**

Visible emissions may be measured using either of the following:

- (1) A device approved by the Department and maintained to provide accurate opacity measurements.
- (2) Observers, trained and certified in EPA Method 9, to measure plume opacity with the naked eye or with the aid of any devices approved by the Department.

010 [25 Pa. Code §127.441]**Operating permit terms and conditions.**

The permittee shall conduct a weekly inspection Monday through Friday, except holidays, around the plant periphery during daylight hours when the plant is in production to detect visible emissions, fugitive emissions, and odorous emissions as follows:

- (a) Visible emissions in excess of the limits stated in Section C, Condition #004. Visible emissions may be measured according to the methods specified in Section C, Condition #009, or as an alternative, plant personnel who observe visible emissions may report the incidence of visible emissions to a trained observer. If visible emission are determined by a trained observer to be in excess of the limit stated in Section C, Condition #004, the Department shall be notified within two hours of each incident.

**SECTION C. Site Level Requirements**

(b) the presence of fugitive emissions beyond the plant boundaries as stated in Section C, Condition #002.

(c) the presence of odorous air emissions beyond the plant boundaries as stated in Section C, Condition #003

IV. RECORDKEEPING REQUIREMENTS.**# 011 [25 Pa. Code §127.441]****Operating permit terms and conditions.**

The permittee shall keep monthly records of the quantity and type of solvents/binders used, generated, recycled on-site, disposed of off-site, records of the metal poured, throughput rates, and VOCs emitted into the atmosphere.

012 [25 Pa. Code §127.441]**Operating permit terms and conditions.**

The permittee shall maintain a logbook for recording the status of odorous air contaminants, visible emissions and fugitive emissions exceedences. The logbook shall also include the name of the company representative, the date and time that the monitoring was conducted and wind direction.

Note: A log entry is required for each of the above weekly inspections regardless of whether or not an exceedence has occurred.

013 [25 Pa. Code §127.441]**Operating permit terms and conditions.**

The permittee shall maintain a record of manufacturer supplied VOC Data Sheets or Material Safety Data Sheets for all binders/solvents and coatings used at this facility within the most recent five (5) year period. The record shall be made available to the Department upon request.

V. REPORTING REQUIREMENTS.**# 014 [25 Pa. Code §127.441]****Operating permit terms and conditions.**

The permittee shall submit an annual emissions report for NO_x, SO_x, CO, PM, HAPs, and VOCs including various binders/solvents used in different foundry operations, including VOCs in binders/solvents, consumption of binders/solvents on a monthly basis, pounds per month VOC emissions, and total hours per year of operation, to the Lancaster District Supervisor. Each report (January 1 through December 31) is due no later than March 1 of the following year for each operating year authorized by the permit or its renewal.

015 [25 Pa. Code §127.512]**Operating permit terms and conditions.**

(a) The permittee shall report malfunctions which occur at the facility to the Department. As defined in 40 CFR § 60.2 and incorporated by reference in 25 Pa. Code Chapter 122, a malfunction is any sudden, infrequent and not reasonably preventable failure or air pollution control equipment, process equipment, or a process to operate in a normal or usual manner. Failures caused in part by poor maintenance or careless operation are not malfunctions. Malfunctions shall be reported as follows:

(1) Malfunctions which occur at the facility which pose an imminent danger to public health, safety, welfare and the environment, shall be immediately reported to the Department by the telephone. The telephone report of such malfunctions shall occur no later than two (2) hours after the permittee is aware of the malfunction. The permittee shall submit a written report of instance of such malfunctions to the Department within three (3) days of the telephone report.

(2) Unless otherwise required by this permit, any other malfunction that is not subject to the reporting requirements of paragraph (1) above, shall be reported to the Department, in writing, within five (5) days of discovery of the malfunction.

(b) Malfunctions shall be reported to the Department at the following address:

PADEP
Air Quality Program
909 Elmerton Avenue

**SECTION C. Site Level Requirements**

Harrisburg, PA 17110

Telephone reports can be made to the Air Quality Program at (814) 946-7290 during normal business hours, or to the Department's Emergency Hotline at any time. The Emergency Hotline phone number is changed/updated periodically. The current Emergency Hotline phone number can be found at <https://www.dep.pa.gov/About/Regional/SouthcentralRegion/Pages/default.aspx>.

VI. WORK PRACTICE REQUIREMENTS.**# 016 [25 Pa. Code §123.1]****Prohibition of certain fugitive emissions**

A person responsible for sources specified in Site Level Requirements condition #001 shall take all reasonable actions to prevent particulate matter from becoming airborne. These actions shall include, but not be limited to, the following:

- (1) Use, where possible, of water or chemicals for control of dust in the demolition of buildings or structures, construction operations, the grading of roads, or the clearing of land.
- (2) Application of asphalt, oil, water or suitable chemicals on dirt roads, material stockpiles and other surfaces which may give rise to airborne dusts.
- (3) Paving and maintenance of roadways.
- (4) Prompt removal of earth or other material from paved streets onto which earth or other material has been transported by trucking or earth moving equipment, erosion by water, or other means.

017 [25 Pa. Code §127.441]**Operating permit terms and conditions.**

The permittee shall operate and maintain instrumentation to measure the fan current and the pressure drop across the fabric collectors.

018 [25 Pa. Code §127.441]**Operating permit terms and conditions.**

The permittee shall maintain and operate the sources and the air cleaning devices consistent with good operating and maintenance practices and operate in a manner as not to cause air pollution.

VII. ADDITIONAL REQUIREMENTS.**# 019 [25 Pa. Code §127.513]****Compliance certification.**

The permittee shall forward EPA the annual compliance certification report as defined in Condition #024 of Section B, electronically, in lieu of a hard copy version, to the email address: R3_APD_Permits@epa.gov

020 [25 Pa. Code §129.14]**Open burning operations**

- (a) No person shall conduct the open burning of materials in such a manner that:
- (1) The emissions are visible, at any time, at the point such emissions pass outside the property of the person on whose land the open burning is being conducted.
 - (2) Malodorous air contaminants from the open burning are detectable outside the property of the person on whose land the open burning is being conducted.
 - (3) The emissions interfere with the reasonable enjoyment of life or property.
 - (4) The emissions cause damage to vegetation or property.

**SECTION C. Site Level Requirements**

(5) The emissions are or may be deleterious to human or animal health.

(b) The above requirements do not apply where the open burning operations result from:

(1) A fire set to prevent or abate a fire hazard, when approved by the Department and set by or under the supervision of a public officer.

(2) A fire set for the purpose of instructing personnel in fire fighting, when approved by the Department.

(3) A fire set for the prevention and control of disease or pests, when approved by the Department.

(4) A fire set solely for recreational or ceremonial purposes.

(5) A fire set solely for cooking food.

(c) This permit condition does not constitute authorization to burn solid waste in violation of Section 610(3) of the Solid Waste Management Act (SWMA), contained at 35 P.S. Section 6018.610(3), or any other provision of the SWMA.

VIII. COMPLIANCE CERTIFICATION.

The permittee shall submit within thirty days of 01/01/2020 a certificate of compliance with all permit terms and conditions set forth in this Title V permit as required under condition #026 of section B of this permit, and annually thereafter.

IX. COMPLIANCE SCHEDULE.

No compliance milestones exist.

***** Permit Shield In Effect *****

**SECTION D. Source Level Requirements**

Source ID: 033

Source Name: SUPERIOR/MOHAWK BOILER

Source Capacity/Throughput:

2.900 MCF/HR

Natural Gas

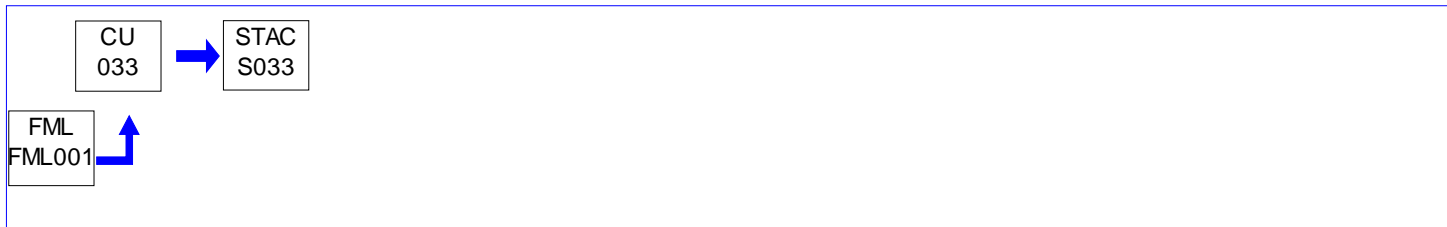
**I. RESTRICTIONS.****Emission Restriction(s).**

001 [25 Pa. Code §123.11]

Combustion units

No person shall permit the emissions into the outdoor atmosphere of particulate matter from a combustion unit in excess of the rate of 0.4 pounds per million Btu of heat input.

002 [25 Pa. Code §123.22]

Combustion units

No person shall permit the emission into the outdoor atmosphere of sulfur oxides, expressed as SO₂, in excess of the rate of 4 pounds per million Btu of heat input.

003 [25 Pa. Code §127.441]

Operating permit terms and conditions.

The permittee shall operate the source on commercial natural gas only.

II. TESTING REQUIREMENTS.

No additional testing requirements exist except as provided in other sections of this permit including Section B (Title V General Requirements).

III. MONITORING REQUIREMENTS.

No additional monitoring requirements exist except as provided in other sections of this permit including Section B (Title V General Requirements).

IV. RECORDKEEPING REQUIREMENTS.

No additional record keeping requirements exist except as provided in other sections of this permit including Section B (Title V General Requirements).

V. REPORTING REQUIREMENTS.

No additional reporting requirements exist except as provided in other sections of this permit including Section B (Title V General Requirements).

VI. WORK PRACTICE REQUIREMENTS.

No additional work practice requirements exist except as provided in other sections of this permit including Section B (Title V General Requirements).

**SECTION D. Source Level Requirements****VII. ADDITIONAL REQUIREMENTS.**

No additional requirements exist except as provided in other sections of this permit including Section B (Title V General Requirements).

***** Permit Shield in Effect. *****

**SECTION D. Source Level Requirements**

Source ID: 036A

Source Name: JOHNSTON BOILER

Source Capacity/Throughput:

25.100 MCF/HR

Natural Gas

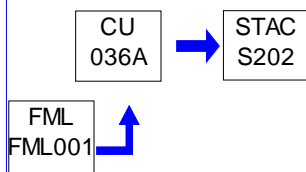
**I. RESTRICTIONS.****Emission Restriction(s).****# 001 [25 Pa. Code §123.11]****Combustion units**

No person shall permit the emissions into the outdoor atmosphere of particulate matter from a combustion unit in excess of the rate of 0.4 pounds per million Btu of heat input.

002 [25 Pa. Code §123.22]**Combustion units**

No person shall permit the emission into the outdoor atmosphere of sulfur oxides, expressed as SO₂, in excess of the rate of 4 pounds per million Btu of heat input.

003 [25 Pa. Code §127.441]**Operating permit terms and conditions.**

The permittee shall operate the source on commercial natural gas only.

II. TESTING REQUIREMENTS.

No additional testing requirements exist except as provided in other sections of this permit including Section B (Title V General Requirements).

III. MONITORING REQUIREMENTS.

No additional monitoring requirements exist except as provided in other sections of this permit including Section B (Title V General Requirements).

IV. RECORDKEEPING REQUIREMENTS.**# 004 [40 CFR Part 60 Standards of Performance for New Stationary Sources §40 CFR 60.48c]****Subpart Dc - Standards of Performance for Small Industrial- Commercial-Institutional Steam Generating Units Reporting and recordkeeping requirements.**

[Additional authority for this condition is derived from 25 Pa Code Section 127.511]

The permittee shall maintain records of all natural gas purchased for the most recent five year period. These records shall be available to the Department representative upon request.



SECTION D. Source Level Requirements

V. REPORTING REQUIREMENTS.

No additional reporting requirements exist except as provided in other sections of this permit including Section B (Title V General Requirements).

VI. WORK PRACTICE REQUIREMENTS.

No additional work practice requirements exist except as provided in other sections of this permit including Section B (Title V General Requirements).

VII. ADDITIONAL REQUIREMENTS.

No additional requirements exist except as provided in other sections of this permit including Section B (Title V General Requirements).

***** Permit Shield in Effect. *****

**SECTION D. Source Level Requirements**

Source ID: 034

Source Name: MISC. GAS USAGE

Source Capacity/Throughput:

55.000 MCF/HR

Natural Gas

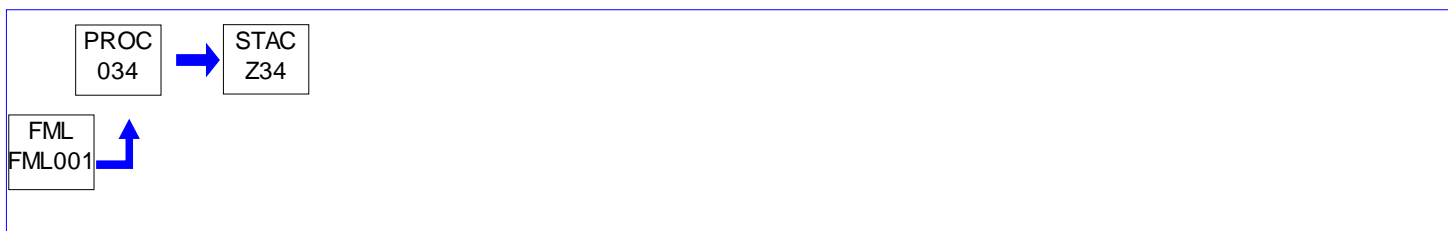
**I. RESTRICTIONS.****Emission Restriction(s).**

001 [25 Pa. Code §123.21]

General

No person shall permit the emission into the outdoor atmosphere of sulfur oxides from the above source in a manner that the concentration of the sulfur oxides, expressed as SO₂, in the effluent gas exceeds 500 parts per million, by volume, dry basis.

II. TESTING REQUIREMENTS.

No additional testing requirements exist except as provided in other sections of this permit including Section B (Title V General Requirements).

III. MONITORING REQUIREMENTS.

No additional monitoring requirements exist except as provided in other sections of this permit including Section B (Title V General Requirements).

IV. RECORDKEEPING REQUIREMENTS.

No additional record keeping requirements exist except as provided in other sections of this permit including Section B (Title V General Requirements).

V. REPORTING REQUIREMENTS.

No additional reporting requirements exist except as provided in other sections of this permit including Section B (Title V General Requirements).

VI. WORK PRACTICE REQUIREMENTS.

No additional work practice requirements exist except as provided in other sections of this permit including Section B (Title V General Requirements).

VII. ADDITIONAL REQUIREMENTS.

No additional requirements exist except as provided in other sections of this permit including Section B (Title V General Requirements).

***** Permit Shield in Effect. *****

**SECTION D. Source Level Requirements**

Source ID: 130

Source Name: HOT DIP GALVANIZING #4 KETTLE

Source Capacity/Throughput:

1.300 Tons/HR

CASTINGS

Conditions for this source occur in the following groups: GROUP 002

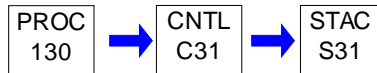
**I. RESTRICTIONS.**

No additional requirements exist except as provided in other sections of this permit including Section B (Title V General Requirements) and/or Section E (Source Group Restrictions).

II. TESTING REQUIREMENTS.

No additional testing requirements exist except as provided in other sections of this permit including Section B (Title V General Requirements) and/or Section E (Source Group Restrictions).

III. MONITORING REQUIREMENTS.

No additional monitoring requirements exist except as provided in other sections of this permit including Section B (Title V General Requirements) and/or Section E (Source Group Restrictions).

IV. RECORDKEEPING REQUIREMENTS.

No additional record keeping requirements exist except as provided in other sections of this permit including Section B (Title V General Requirements) and/or Section E (Source Group Restrictions).

V. REPORTING REQUIREMENTS.

No additional reporting requirements exist except as provided in other sections of this permit including Section B (Title V General Requirements) and/or Section E (Source Group Restrictions).

VI. WORK PRACTICE REQUIREMENTS.

No additional work practice requirements exist except as provided in other sections of this permit including Section B (Title V General Requirements) and/or Section E (Source Group Restrictions).

VII. ADDITIONAL REQUIREMENTS.

No additional requirements exist except as provided in other sections of this permit including Section B (Title V General Requirements) and/or Section E (Source Group Restrictions).

***** Permit Shield in Effect. *****

**SECTION D. Source Level Requirements**

Source ID: 131

Source Name: HOT DIP GALVANIZING #5 KETTLE

Source Capacity/Throughput:	1.900 Tons/HR	CASTINGS
	3.000 MCF/HR	Natural Gas

Conditions for this source occur in the following groups: GROUP 002

**I. RESTRICTIONS.**

No additional requirements exist except as provided in other sections of this permit including Section B (Title V General Requirements) and/or Section E (Source Group Restrictions).

II. TESTING REQUIREMENTS.

No additional testing requirements exist except as provided in other sections of this permit including Section B (Title V General Requirements) and/or Section E (Source Group Restrictions).

III. MONITORING REQUIREMENTS.

No additional monitoring requirements exist except as provided in other sections of this permit including Section B (Title V General Requirements) and/or Section E (Source Group Restrictions).

IV. RECORDKEEPING REQUIREMENTS.

No additional record keeping requirements exist except as provided in other sections of this permit including Section B (Title V General Requirements) and/or Section E (Source Group Restrictions).

V. REPORTING REQUIREMENTS.

No additional reporting requirements exist except as provided in other sections of this permit including Section B (Title V General Requirements) and/or Section E (Source Group Restrictions).

VI. WORK PRACTICE REQUIREMENTS.

No additional work practice requirements exist except as provided in other sections of this permit including Section B (Title V General Requirements) and/or Section E (Source Group Restrictions).

VII. ADDITIONAL REQUIREMENTS.

No additional requirements exist except as provided in other sections of this permit including Section B (Title V General Requirements) and/or Section E (Source Group Restrictions).

***** Permit Shield in Effect. *****

**SECTION D. Source Level Requirements**

Source ID: 187

Source Name: SPRUE CRUSHER

Source Capacity/Throughput: 50.000 Tons/HR IRON

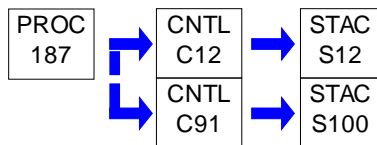
**I. RESTRICTIONS.****Emission Restriction(s).**

001 [25 Pa. Code §123.13]

Processes

No person shall permit the emission into the outdoor atmosphere of particulate matter from each of the Wheelabrator fabric filters #430 and #DC-446, at any time, in such a manner that the concentration of particulate matter in the effluent gas exceeds 0.01 grains per dry standard cubic foot.

II. TESTING REQUIREMENTS.

No additional testing requirements exist except as provided in other sections of this permit including Section B (Title V General Requirements).

III. MONITORING REQUIREMENTS.

No additional monitoring requirements exist except as provided in other sections of this permit including Section B (Title V General Requirements).

IV. RECORDKEEPING REQUIREMENTS.

No additional record keeping requirements exist except as provided in other sections of this permit including Section B (Title V General Requirements).

V. REPORTING REQUIREMENTS.

No additional reporting requirements exist except as provided in other sections of this permit including Section B (Title V General Requirements).

VI. WORK PRACTICE REQUIREMENTS.

002 [25 Pa. Code §127.441]

Operating permit terms and conditions.

In order to assure compliance with the requirement of Condition #001 above, the permittee shall be required to perform the following:

(1) Monitor and record the pressure drop across each of the above baghouses on a weekly basis. The permittee shall review each reading with the manufacturer's suggested pressure drop operating range for the baghouses. In the event the pressure drop readings are not within the manufacturer's recommended operating range, the permittee shall take corrective actions to return the operations of the baghouse to within the recommended operating range.

(2) Each reading shall be entered in a logbook indicating the date and time the reading was taken, the name of the company

**SECTION D. Source Level Requirements**

representative taking the reading, the manufacturer's recommended operating range, and any corrective actions or maintenance performed. The logbook shall be maintained at the facility for a period of five (5) years and be made available to the Department upon request.

VII. ADDITIONAL REQUIREMENTS.

No additional requirements exist except as provided in other sections of this permit including Section B (Title V General Requirements).

***** Permit Shield in Effect. *****

**SECTION D. Source Level Requirements**

Source ID: 188

Source Name: MELT OPERATIONS

Source Capacity/Throughput: 44.000 Tons/HR IRON

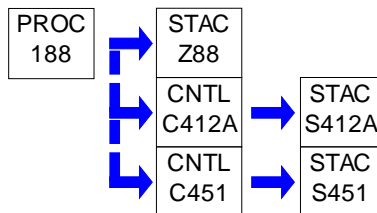
Conditions for this source occur in the following groups: GROUP 003
GROUP 004**I. RESTRICTIONS.****Emission Restriction(s).**

001 [25 Pa. Code §123.13]

Processes

No person shall permit the emission into the outdoor atmosphere of particulate matter from each of the Wheelabrator fabric filters #DC-412 and #DC-451, at any time, in such a manner that the concentration of particulate matter in the effluent gas exceeds .01 grains per dry standard cubic foot.

II. TESTING REQUIREMENTS.

No additional testing requirements exist except as provided in other sections of this permit including Section B (Title V General Requirements) and/or Section E (Source Group Restrictions).

III. MONITORING REQUIREMENTS.

No additional monitoring requirements exist except as provided in other sections of this permit including Section B (Title V General Requirements) and/or Section E (Source Group Restrictions).

IV. RECORDKEEPING REQUIREMENTS.

No additional record keeping requirements exist except as provided in other sections of this permit including Section B (Title V General Requirements) and/or Section E (Source Group Restrictions).

V. REPORTING REQUIREMENTS.

No additional reporting requirements exist except as provided in other sections of this permit including Section B (Title V General Requirements) and/or Section E (Source Group Restrictions).

VI. WORK PRACTICE REQUIREMENTS.

No additional work practice requirements exist except as provided in other sections of this permit including Section B (Title V General Requirements) and/or Section E (Source Group Restrictions).

VII. ADDITIONAL REQUIREMENTS.

No additional requirements exist except as provided in other sections of this permit including Section B (Title V General Requirements) and/or Section E (Source Group Restrictions).



SECTION D. Source Level Requirements

***** Permit Shield in Effect. *****

**SECTION D. Source Level Requirements**

Source ID: 189

Source Name: (2) SCRAP PREHEATERS

Source Capacity/Throughput:

40.000 Tons/HR

IRON SCRAP

Conditions for this source occur in the following groups: GROUP 002

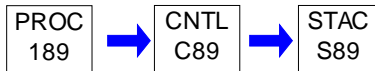
**I. RESTRICTIONS.**

No additional requirements exist except as provided in other sections of this permit including Section B (Title V General Requirements) and/or Section E (Source Group Restrictions).

II. TESTING REQUIREMENTS.

No additional testing requirements exist except as provided in other sections of this permit including Section B (Title V General Requirements) and/or Section E (Source Group Restrictions).

III. MONITORING REQUIREMENTS.

No additional monitoring requirements exist except as provided in other sections of this permit including Section B (Title V General Requirements) and/or Section E (Source Group Restrictions).

IV. RECORDKEEPING REQUIREMENTS.

No additional record keeping requirements exist except as provided in other sections of this permit including Section B (Title V General Requirements) and/or Section E (Source Group Restrictions).

V. REPORTING REQUIREMENTS.

No additional reporting requirements exist except as provided in other sections of this permit including Section B (Title V General Requirements) and/or Section E (Source Group Restrictions).

VI. WORK PRACTICE REQUIREMENTS.

No additional work practice requirements exist except as provided in other sections of this permit including Section B (Title V General Requirements) and/or Section E (Source Group Restrictions).

VII. ADDITIONAL REQUIREMENTS.

No additional requirements exist except as provided in other sections of this permit including Section B (Title V General Requirements) and/or Section E (Source Group Restrictions).

***** Permit Shield in Effect. *****

**SECTION D. Source Level Requirements**

Source ID: 190

Source Name: BURN OFF FURNACE

Source Capacity/Throughput:

10.000 Lbs/HR

HANGERS

0.700 MCF/HR

Natural Gas

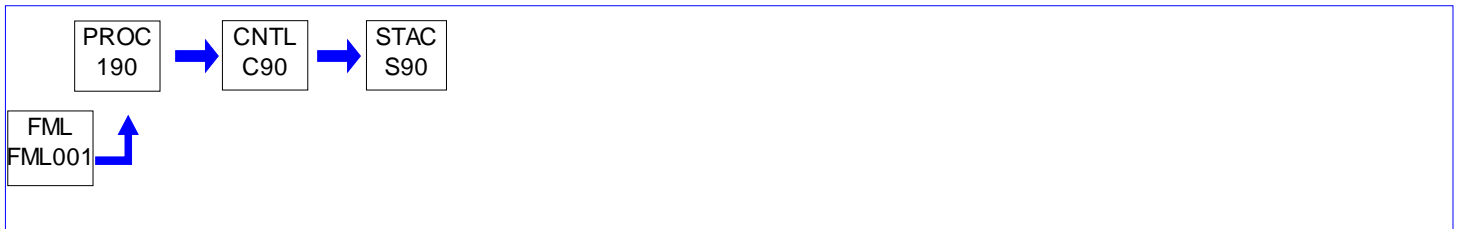
**I. RESTRICTIONS.****Emission Restriction(s).****# 001 [25 Pa. Code §127.441]****Operating permit terms and conditions.**

[Additional authority for the following conditions were derived from GP4-36-05019]

- (1) The afterburner chamber temperature shall be maintained at 1,400 F or greater at a minimum gas retention time of 0.5 seconds.
- (2) The burn off oven shall not at any time result in the emissions of particulate matter emissions in excess of 0.02 gr/dscf corrected to 12% CO₂.
- (3) The burn off oven shall not be used to burn coatings that contain halogenated hydrocarbons like PVC or Teflons.
- (4) The burn off oven shall not at any time result in the emission of sulfur compounds in excess of 500 ppm, by volume, dry absis, as specified in 25 Pa. Code Section 123.21.
- (5) The permittee shall operate and maintain a temperature indicator and recorder to measure and record the temperature in the secondary chamber of the burn off oven.

002 [25 Pa. Code §127.441]**Operating permit terms and conditions.**

The source shall be equipped with an interlock system to ensure that the afterburner chamber reaches it's operating temperature prior to activating the primary burner.

II. TESTING REQUIREMENTS.

No additional testing requirements exist except as provided in other sections of this permit including Section B (Title V General Requirements).

III. MONITORING REQUIREMENTS.

No additional monitoring requirements exist except as provided in other sections of this permit including Section B (Title V General Requirements).

IV. RECORDKEEPING REQUIREMENTS.

No additional record keeping requirements exist except as provided in other sections of this permit including Section B (Title V General Requirements).



SECTION D. Source Level Requirements

V. REPORTING REQUIREMENTS.

No additional reporting requirements exist except as provided in other sections of this permit including Section B (Title V General Requirements).

VI. WORK PRACTICE REQUIREMENTS.

No additional work practice requirements exist except as provided in other sections of this permit including Section B (Title V General Requirements).

VII. ADDITIONAL REQUIREMENTS.

No additional requirements exist except as provided in other sections of this permit including Section B (Title V General Requirements).

***** Permit Shield in Effect. *****

**SECTION D. Source Level Requirements**

Source ID: 191

Source Name: SURFACE COATING DIP LINE

Source Capacity/Throughput:

10.000 Lbs/HR

SOLVENT

Conditions for this source occur in the following groups: GROUP 005

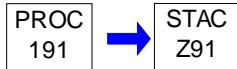
**I. RESTRICTIONS.**

No additional requirements exist except as provided in other sections of this permit including Section B (Title V General Requirements) and/or Section E (Source Group Restrictions).

II. TESTING REQUIREMENTS.**# 001 [25 Pa. Code §127.441]****Operating permit terms and conditions.**

The permittee shall demonstrate the VOC/HAP content of each surface coating by one of the following methods:

(a) For surface coatings applied as they are received from the manufacturer, the permittee may demonstrate compliance with the applicable standard by obtaining EPA Method 24 certification testing from the manufacturer, or by maintaining VOC/HAP data sheets from the manufacturer.

(b) In the absence of EPA Method 24 certification testing from the manufacturer, or VOC/HAP data sheets from the manufacturer, allowed under part (a), above, the permittee shall perform EPA Method 24 certification testing on all surface coatings applied as received from the manufacturer.

(c) The permittee may use calculated VOC content values in lieu of EPA Method 24 certification testing for multi-part surface coatings where the permittee maintains VOC/HAP data sheets for all surface coating constituents (i.e. coatings, pigments, thinners/cutting solvents), and also maintains documentation from the manufacturer as to the recommended mix ratio of the parts. In the event of any inconsistency between the calculated VOC content and data obtained from EPA Method 24 certification testing, the latter shall take precedence.

III. MONITORING REQUIREMENTS.

No additional monitoring requirements exist except as provided in other sections of this permit including Section B (Title V General Requirements) and/or Section E (Source Group Restrictions).

IV. RECORDKEEPING REQUIREMENTS.**# 002 [25 Pa. Code §127.441]****Operating permit terms and conditions.**

The permittee shall maintain records of all EPA Method 24 certification testing performed (or VOC/HAP data sheets), as well as any solids content testing performed, in accordance with Condition #001 above for the most recent two (2) year period. The records shall be made available to the Department upon request.

003 [25 Pa. Code §129.52]**Surface coating processes**

The permittee shall maintain records sufficient to demonstrate compliance with this section. At a minimum, the facility shall maintain daily records of:

(1) The following parameters for each coating, thinner and other component as supplied:

(i) The coating, thinner or component name and identification number.

**SECTION D. Source Level Requirements**

- (ii) The volume used.
 - (iii) The mix ratio.
 - (iv) The density or specific gravity.
 - (v) The weight percent of total volatiles, water, solids and exempt solvents.
 - (vi) The volume percent of solids for Table I surface coating process categories 1-10.
- (2) The VOC content of each coating, thinner and other component as supplied.
- (3) The VOC content of each as applied coating.

V. REPORTING REQUIREMENTS.

No additional reporting requirements exist except as provided in other sections of this permit including Section B (Title V General Requirements) and/or Section E (Source Group Restrictions).

VI. WORK PRACTICE REQUIREMENTS.

No additional work practice requirements exist except as provided in other sections of this permit including Section B (Title V General Requirements) and/or Section E (Source Group Restrictions).

VII. ADDITIONAL REQUIREMENTS.

No additional requirements exist except as provided in other sections of this permit including Section B (Title V General Requirements) and/or Section E (Source Group Restrictions).

***** Permit Shield in Effect. *****

**SECTION D. Source Level Requirements**

Source ID: 196

Source Name: WASHERS

Source Capacity/Throughput:

50.000 Lbs/HR

SOLVENT

Conditions for this source occur in the following groups: GROUP 007

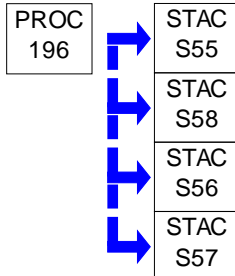
**I. RESTRICTIONS.**

No additional requirements exist except as provided in other sections of this permit including Section B (Title V General Requirements) and/or Section E (Source Group Restrictions).

II. TESTING REQUIREMENTS.

No additional testing requirements exist except as provided in other sections of this permit including Section B (Title V General Requirements) and/or Section E (Source Group Restrictions).

III. MONITORING REQUIREMENTS.

No additional monitoring requirements exist except as provided in other sections of this permit including Section B (Title V General Requirements) and/or Section E (Source Group Restrictions).

IV. RECORDKEEPING REQUIREMENTS.

No additional record keeping requirements exist except as provided in other sections of this permit including Section B (Title V General Requirements) and/or Section E (Source Group Restrictions).

V. REPORTING REQUIREMENTS.

No additional reporting requirements exist except as provided in other sections of this permit including Section B (Title V General Requirements) and/or Section E (Source Group Restrictions).

VI. WORK PRACTICE REQUIREMENTS.

No additional work practice requirements exist except as provided in other sections of this permit including Section B (Title V General Requirements) and/or Section E (Source Group Restrictions).

VII. ADDITIONAL REQUIREMENTS.

No additional requirements exist except as provided in other sections of this permit including Section B (Title V General Requirements) and/or Section E (Source Group Restrictions).

***** Permit Shield in Effect. *****

**SECTION D. Source Level Requirements**

Source ID: 197

Source Name: PARTS CLEANERS

Source Capacity/Throughput:

20.000 Lbs/HR

SOLVENT

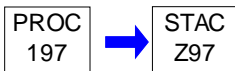
**I. RESTRICTIONS.****Emission Restriction(s).****# 001 [25 Pa. Code §129.63]****Degreasing operations**

- (a) The cold cleaning machines associated with the above operations shall each have a freeboard ratio of 0.50 or greater.
- (b) The permittee may not use, sell or offer for sale for use in a cold cleaning machine any solvent with a vapor pressure of 1.0 millimeter of mercury (mm Hg) or greater and containing greater than 5% VOC by weight, measured at 20°C (68°F) containing VOCs. This condition does not apply to the following Cold Cleaning Machines:
- (1) To immersion cold cleaning machines used in extreme cleaning service.
 - (2) Machines, in which the Department approves in writing, that compliance with this condition will result in unsafe operating conditions.
 - (3) To immersion cold cleaning machines with a freeboard ratio equal to or greater than 0.75.

II. TESTING REQUIREMENTS.

No additional testing requirements exist except as provided in other sections of this permit including Section B (Title V General Requirements).

III. MONITORING REQUIREMENTS.

No additional monitoring requirements exist except as provided in other sections of this permit including Section B (Title V General Requirements).

IV. RECORDKEEPING REQUIREMENTS.**# 002 [25 Pa. Code §129.63]****Degreasing operations**

The permittee shall maintain for at least two (2) years and shall provide to the Department, on request, the following information:

- (1) The name and address of the solvent supplier.
- (2) The type of solvent including the product or vendor identification number.
- (3) The vapor pressure of the solvent measured in mm hg at 20°C (68°F).

An invoice, bill of sale, certificate that corresponds to a number of sales, Material Safety Data Sheet (MSDS), or other appropriate documentation acceptable to the Department may be used to comply with this section.

**SECTION D. Source Level Requirements****V. REPORTING REQUIREMENTS.**

No additional reporting requirements exist except as provided in other sections of this permit including Section B (Title V General Requirements).

VI. WORK PRACTICE REQUIREMENTS.**# 003 [25 Pa. Code §129.63]****Degreasing operations**

The permittee shall operate the cold cleaning machines in accordance with the following procedures:

- (1) Waste solvent shall be collected and stored in closed containers. The closed containers may contain a device that allows pressure relief, but does not allow liquid solvent to drain from the container.
- (2) Flushing of parts using a flexible hose or other flushing device shall be performed only within the cold cleaning machine. The solvent spray shall be a solid fluid stream, not an atomized or shower spray.
- (3) Sponges, fabric, wood, leather, paper products and other absorbent materials may not be cleaned in the cold cleaning machine.
- (4) Air agitated solvent baths may not be used.
- (5) Spills during solvent transfer and use of the cold cleaning machine shall be cleaned up immediately.

004 [25 Pa. Code §129.63]**Degreasing operations**

(a) The cold cleaning machines associated with the above operations shall have a permanent, conspicuous label summarizing the operating requirements of Condition #004 below. In addition, the label shall include the following discretionary good operating practices:

- (1) Cleaned parts should be drained at least 15 seconds or until dripping ceases, whichever is longer. Parts having cavities or blind holes shall be tipped or rotated while the part is draining. During the draining, tipping or rotating, the parts should be positioned so that solvent drains directly back to the cold cleaning machine.
- (2) When a pump-agitated solvent bath is used, the agitator should be operated to produce a rolling motion of the solvent with no observable splashing of the solvent against the tank walls or the parts being cleaned.
- (3) Work area fans should be located and positioned so that they do not blow across the opening of the degreaser unit.

(b) Be equipped with a cover that shall be closed at all times except during cleaning of parts or the addition or removal of solvent. For remote reservoir cold cleaning machines which drain directly into the solvent storage reservoir, a perforated drain with a diameter of not more than six inches shall constitute an acceptable cover.

VII. ADDITIONAL REQUIREMENTS.

No additional requirements exist except as provided in other sections of this permit including Section B (Title V General Requirements).

***** Permit Shield in Effect. *****

**SECTION D. Source Level Requirements**

Source ID: 199

Source Name: ANNEALING

Source Capacity/Throughput:

9.500 Tons/HR

CASTINGS

Conditions for this source occur in the following groups: GROUP 006
GROUP 008

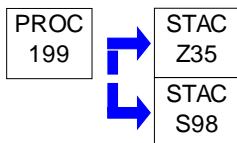
**I. RESTRICTIONS.****Emission Restriction(s).**

001 [25 Pa. Code §123.13]

Processes

No person shall permit the emission into the outdoor atmosphere of particulate matter from the above source, at any time, in such a manner that the concentration of particulate matter in the effluent gas exceeds 0.04 grain per dry standard cubic foot.

II. TESTING REQUIREMENTS.

No additional testing requirements exist except as provided in other sections of this permit including Section B (Title V General Requirements) and/or Section E (Source Group Restrictions).

III. MONITORING REQUIREMENTS.

No additional monitoring requirements exist except as provided in other sections of this permit including Section B (Title V General Requirements) and/or Section E (Source Group Restrictions).

IV. RECORDKEEPING REQUIREMENTS.

No additional record keeping requirements exist except as provided in other sections of this permit including Section B (Title V General Requirements) and/or Section E (Source Group Restrictions).

V. REPORTING REQUIREMENTS.

No additional reporting requirements exist except as provided in other sections of this permit including Section B (Title V General Requirements) and/or Section E (Source Group Restrictions).

VI. WORK PRACTICE REQUIREMENTS.

No additional work practice requirements exist except as provided in other sections of this permit including Section B (Title V General Requirements) and/or Section E (Source Group Restrictions).

VII. ADDITIONAL REQUIREMENTS.

No additional requirements exist except as provided in other sections of this permit including Section B (Title V General Requirements) and/or Section E (Source Group Restrictions).

***** Permit Shield in Effect. *****

**SECTION D. Source Level Requirements**

Source ID: 200

Source Name: SHELL CORE

Source Capacity/Throughput:

2.000 Tons/HR

CORES

Conditions for this source occur in the following groups: GROUP 006
GROUP 008

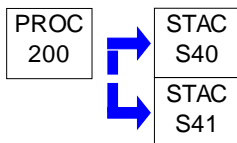
**I. RESTRICTIONS.****Emission Restriction(s).****# 001 [25 Pa. Code §123.13]****Processes**

No person shall permit the emission into the outdoor atmosphere of particulate matter from the above source, at any time, in such a manner that the concentration of particulate matter in the effluent gas exceeds 0.04 grain per dry standard cubic foot.

002 [25 Pa. Code §127.441]**Operating permit terms and conditions.**

[Additional authority for the following condition is derived from plan approval number 36-05019D]

The permittee shall limit the use of resin coated sand consumption from the above operations to no greater than 23,350 tons, based on any consecutive 12-month rolling period.

II. TESTING REQUIREMENTS.

No additional testing requirements exist except as provided in other sections of this permit including Section B (Title V General Requirements) and/or Section E (Source Group Restrictions).

III. MONITORING REQUIREMENTS.

No additional monitoring requirements exist except as provided in other sections of this permit including Section B (Title V General Requirements) and/or Section E (Source Group Restrictions).

IV. RECORDKEEPING REQUIREMENTS.**# 003 [25 Pa. Code §127.441]****Operating permit terms and conditions.**

[Additional authority for the following condition is derived from plan approval number 36-05019D]

The permittee shall maintain records of the monthly usage of the resin coated sand from the shell core machine operations.

V. REPORTING REQUIREMENTS.

No additional reporting requirements exist except as provided in other sections of this permit including Section B (Title V General Requirements) and/or Section E (Source Group Restrictions).



SECTION D. Source Level Requirements

VI. WORK PRACTICE REQUIREMENTS.

No additional work practice requirements exist except as provided in other sections of this permit including Section B (Title V General Requirements) and/or Section E (Source Group Restrictions).

VII. ADDITIONAL REQUIREMENTS.

No additional requirements exist except as provided in other sections of this permit including Section B (Title V General Requirements) and/or Section E (Source Group Restrictions).

***** Permit Shield in Effect. *****

**SECTION D. Source Level Requirements**

Source ID: 201

Source Name: COREMAKING

Source Capacity/Throughput:

3.000 Tons/HR

CORES

Conditions for this source occur in the following groups: GROUP 006
GROUP 008

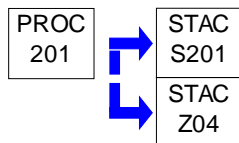
**I. RESTRICTIONS.****Emission Restriction(s).**

001 [25 Pa. Code §123.13]

Processes

No person shall permit the emission into the outdoor atmosphere of particulate matter from the above source, at any time, in such a manner that the concentration of particulate matter in the effluent gas exceeds 0.04 grain per dry standard cubic foot.

II. TESTING REQUIREMENTS.

No additional testing requirements exist except as provided in other sections of this permit including Section B (Title V General Requirements) and/or Section E (Source Group Restrictions).

III. MONITORING REQUIREMENTS.

No additional monitoring requirements exist except as provided in other sections of this permit including Section B (Title V General Requirements) and/or Section E (Source Group Restrictions).

IV. RECORDKEEPING REQUIREMENTS.

No additional record keeping requirements exist except as provided in other sections of this permit including Section B (Title V General Requirements) and/or Section E (Source Group Restrictions).

V. REPORTING REQUIREMENTS.

No additional reporting requirements exist except as provided in other sections of this permit including Section B (Title V General Requirements) and/or Section E (Source Group Restrictions).

VI. WORK PRACTICE REQUIREMENTS.

No additional work practice requirements exist except as provided in other sections of this permit including Section B (Title V General Requirements) and/or Section E (Source Group Restrictions).

VII. ADDITIONAL REQUIREMENTS.

No additional requirements exist except as provided in other sections of this permit including Section B (Title V General Requirements) and/or Section E (Source Group Restrictions).

***** Permit Shield in Effect. *****

**SECTION D. Source Level Requirements**

Source ID: 203

Source Name: COLDBOX COREMAKING

Source Capacity/Throughput:

Conditions for this source occur in the following groups: GROUP 006

GROUP 008

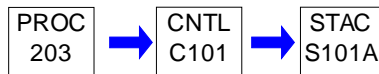
**I. RESTRICTIONS.****Emission Restriction(s).**

001 [25 Pa. Code §127.441]

Operating permit terms and conditions.

[Additional authority for the following conditions were derived from plan approval number 36-05019D & G]

(a) Particulate Matter (PM) emissions from the scrubber exhaust shall not exceed 0.02 gr/dscf.

II. TESTING REQUIREMENTS.

No additional testing requirements exist except as provided in other sections of this permit including Section B (Title V General Requirements) and/or Section E (Source Group Restrictions).

III. MONITORING REQUIREMENTS.

No additional monitoring requirements exist except as provided in other sections of this permit including Section B (Title V General Requirements) and/or Section E (Source Group Restrictions).

IV. RECORDKEEPING REQUIREMENTS.

No additional record keeping requirements exist except as provided in other sections of this permit including Section B (Title V General Requirements) and/or Section E (Source Group Restrictions).

V. REPORTING REQUIREMENTS.

No additional reporting requirements exist except as provided in other sections of this permit including Section B (Title V General Requirements) and/or Section E (Source Group Restrictions).

VI. WORK PRACTICE REQUIREMENTS.

No additional work practice requirements exist except as provided in other sections of this permit including Section B (Title V General Requirements) and/or Section E (Source Group Restrictions).

VII. ADDITIONAL REQUIREMENTS.

No additional requirements exist except as provided in other sections of this permit including Section B (Title V General Requirements) and/or Section E (Source Group Restrictions).

***** Permit Shield in Effect. *****

**SECTION D. Source Level Requirements**

Source ID: 305

Source Name: N.F. CLEANING

Source Capacity/Throughput:

25.000 Tons/HR

CASTINGS

Conditions for this source occur in the following groups: GROUP 002

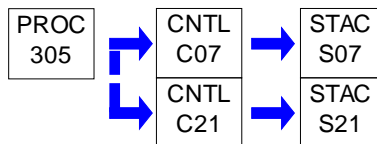
**I. RESTRICTIONS.**

No additional requirements exist except as provided in other sections of this permit including Section B (Title V General Requirements) and/or Section E (Source Group Restrictions).

II. TESTING REQUIREMENTS.

No additional testing requirements exist except as provided in other sections of this permit including Section B (Title V General Requirements) and/or Section E (Source Group Restrictions).

III. MONITORING REQUIREMENTS.

No additional monitoring requirements exist except as provided in other sections of this permit including Section B (Title V General Requirements) and/or Section E (Source Group Restrictions).

IV. RECORDKEEPING REQUIREMENTS.

No additional record keeping requirements exist except as provided in other sections of this permit including Section B (Title V General Requirements) and/or Section E (Source Group Restrictions).

V. REPORTING REQUIREMENTS.

No additional reporting requirements exist except as provided in other sections of this permit including Section B (Title V General Requirements) and/or Section E (Source Group Restrictions).

VI. WORK PRACTICE REQUIREMENTS.

No additional work practice requirements exist except as provided in other sections of this permit including Section B (Title V General Requirements) and/or Section E (Source Group Restrictions).

VII. ADDITIONAL REQUIREMENTS.

No additional requirements exist except as provided in other sections of this permit including Section B (Title V General Requirements) and/or Section E (Source Group Restrictions).

***** Permit Shield in Effect. *****

**SECTION D. Source Level Requirements**

Source ID: 501

Source Name: DISA POURING/CASTING

Source Capacity/Throughput: 36.000 Tons/HR IRON

Conditions for this source occur in the following groups: GROUP 001
 GROUP 003
 GROUP 006
 GROUP 007
 GROUP 008

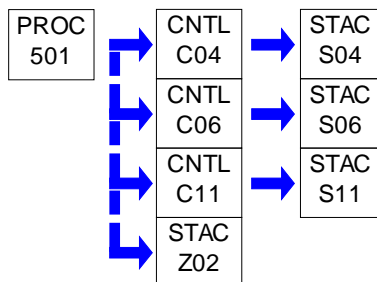
**I. RESTRICTIONS.****Emission Restriction(s).****# 001 [25 Pa. Code §123.13]****Processes**

(a) No person shall permit the emission into the outdoor atmosphere of particulate matter from Wheelabrator fabric filter #426, in a manner, that the concentration of particulate matter in the effluent gas exceeds 0.04 grains per dry standard cubic foot.

(b) No person shall permit the emission into the outdoor atmosphere of particulate matter from Wheelabrator fabric filters #425 and #442, in a manner, that the concentration of particulate matter in the effluent gas exceeds 0.01 grains per dry standard cubic foot.

II. TESTING REQUIREMENTS.

No additional testing requirements exist except as provided in other sections of this permit including Section B (Title V General Requirements) and/or Section E (Source Group Restrictions).

III. MONITORING REQUIREMENTS.

No additional monitoring requirements exist except as provided in other sections of this permit including Section B (Title V General Requirements) and/or Section E (Source Group Restrictions).

IV. RECORDKEEPING REQUIREMENTS.

No additional record keeping requirements exist except as provided in other sections of this permit including Section B (Title V General Requirements) and/or Section E (Source Group Restrictions).

V. REPORTING REQUIREMENTS.

No additional reporting requirements exist except as provided in other sections of this permit including Section B (Title V General Requirements) and/or Section E (Source Group Restrictions).



SECTION D. Source Level Requirements

VI. WORK PRACTICE REQUIREMENTS.

No additional work practice requirements exist except as provided in other sections of this permit including Section B (Title V General Requirements) and/or Section E (Source Group Restrictions).

VII. ADDITIONAL REQUIREMENTS.

No additional requirements exist except as provided in other sections of this permit including Section B (Title V General Requirements) and/or Section E (Source Group Restrictions).

***** Permit Shield in Effect. *****

**SECTION D. Source Level Requirements**

Source ID: 502

Source Name: DISA CASTING/COOLING

Source Capacity/Throughput:

36.000 Tons/HR

CASTINGS

Conditions for this source occur in the following groups: GROUP 001
 GROUP 003
 GROUP 007

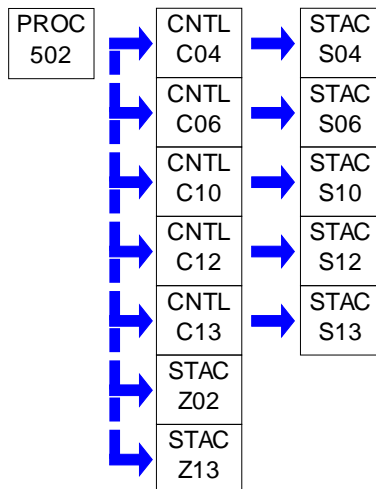
**I. RESTRICTIONS.****Emission Restriction(s).**

001 [25 Pa. Code §123.13]

Processes

(a) No person shall permit the emission into the outdoor atmosphere of particulate matter from each of the ETA or equivalent fabric filters #425 and #426, in a manner, that the concentration of particulate matter in the effluent gas exceeds 0.04 grains per dry standard cubic foot.

(b) No person shall permit the emission into the outdoor atmosphere of particulate matter from each of the Wheelabrator fabric filters #DC-440 and #430, in a manner, that the concentration of particulate matter in the effluent gas exceeds 0.01 grains per dry standard cubic foot.

II. TESTING REQUIREMENTS.

No additional testing requirements exist except as provided in other sections of this permit including Section B (Title V General Requirements) and/or Section E (Source Group Restrictions).

III. MONITORING REQUIREMENTS.

No additional monitoring requirements exist except as provided in other sections of this permit including Section B (Title V General Requirements) and/or Section E (Source Group Restrictions).

IV. RECORDKEEPING REQUIREMENTS.

No additional record keeping requirements exist except as provided in other sections of this permit including Section B (Title V General Requirements) and/or Section E (Source Group Restrictions).



SECTION D. Source Level Requirements

V. REPORTING REQUIREMENTS.

No additional reporting requirements exist except as provided in other sections of this permit including Section B (Title V General Requirements) and/or Section E (Source Group Restrictions).

VI. WORK PRACTICE REQUIREMENTS.

No additional work practice requirements exist except as provided in other sections of this permit including Section B (Title V General Requirements) and/or Section E (Source Group Restrictions).

VII. ADDITIONAL REQUIREMENTS.

No additional requirements exist except as provided in other sections of this permit including Section B (Title V General Requirements) and/or Section E (Source Group Restrictions).

***** Permit Shield in Effect. *****

**SECTION D. Source Level Requirements**

Source ID: 503

Source Name: DISA CASTING/SHAKEOUT

Source Capacity/Throughput: 36.000 Tons/HR CASTINGS

Conditions for this source occur in the following groups: GROUP 001
 GROUP 003
 GROUP 006
 GROUP 007
 GROUP 008

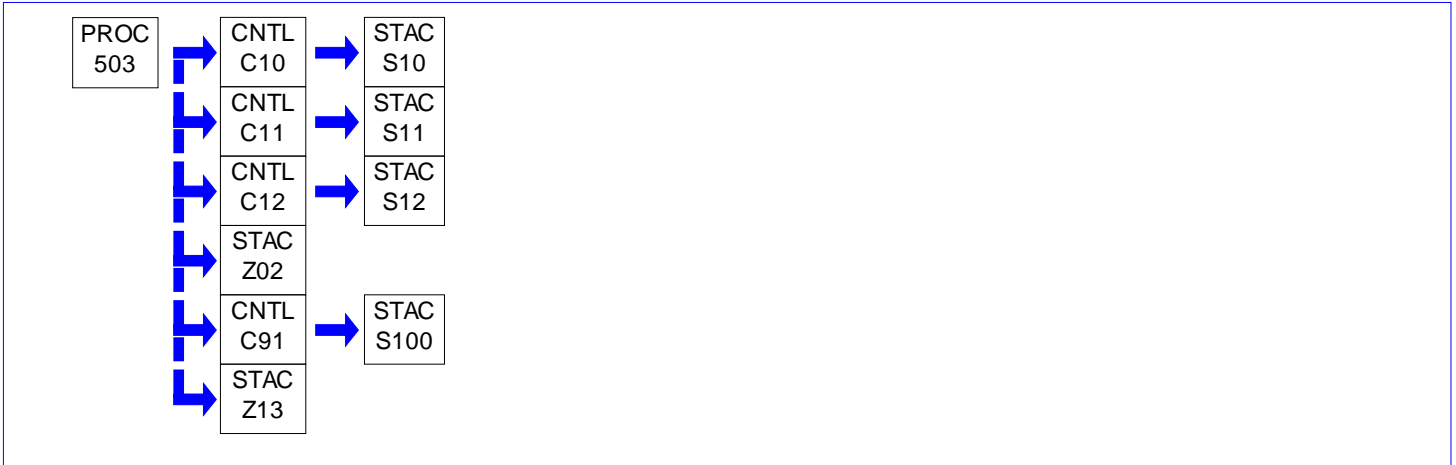
**I. RESTRICTIONS.****Emission Restriction(s).**

001 [25 Pa. Code §123.13]

Processes

No person shall permit the emission into the outdoor atmosphere of particulate matter from each of the Wheelabrator fabric filters #441, #442, #430, and #DC-446, at any time, in such a manner that the concentration of particulate matter in the effluent gas exceeds 0.01 grains per dry standard cubic foot.

II. TESTING REQUIREMENTS.

No additional testing requirements exist except as provided in other sections of this permit including Section B (Title V General Requirements) and/or Section E (Source Group Restrictions).

III. MONITORING REQUIREMENTS.

No additional monitoring requirements exist except as provided in other sections of this permit including Section B (Title V General Requirements) and/or Section E (Source Group Restrictions).

IV. RECORDKEEPING REQUIREMENTS.

No additional record keeping requirements exist except as provided in other sections of this permit including Section B (Title V General Requirements) and/or Section E (Source Group Restrictions).

V. REPORTING REQUIREMENTS.

No additional reporting requirements exist except as provided in other sections of this permit including Section B (Title V General Requirements) and/or Section E (Source Group Restrictions).



SECTION D. Source Level Requirements

VI. WORK PRACTICE REQUIREMENTS.

No additional work practice requirements exist except as provided in other sections of this permit including Section B (Title V General Requirements) and/or Section E (Source Group Restrictions).

VII. ADDITIONAL REQUIREMENTS.

No additional requirements exist except as provided in other sections of this permit including Section B (Title V General Requirements) and/or Section E (Source Group Restrictions).

***** Permit Shield in Effect. *****

**SECTION D. Source Level Requirements**

Source ID: 504

Source Name: DISA SAND SYSTEM

Source Capacity/Throughput: 200.000 Tons/HR SAND

Conditions for this source occur in the following groups: GROUP 003

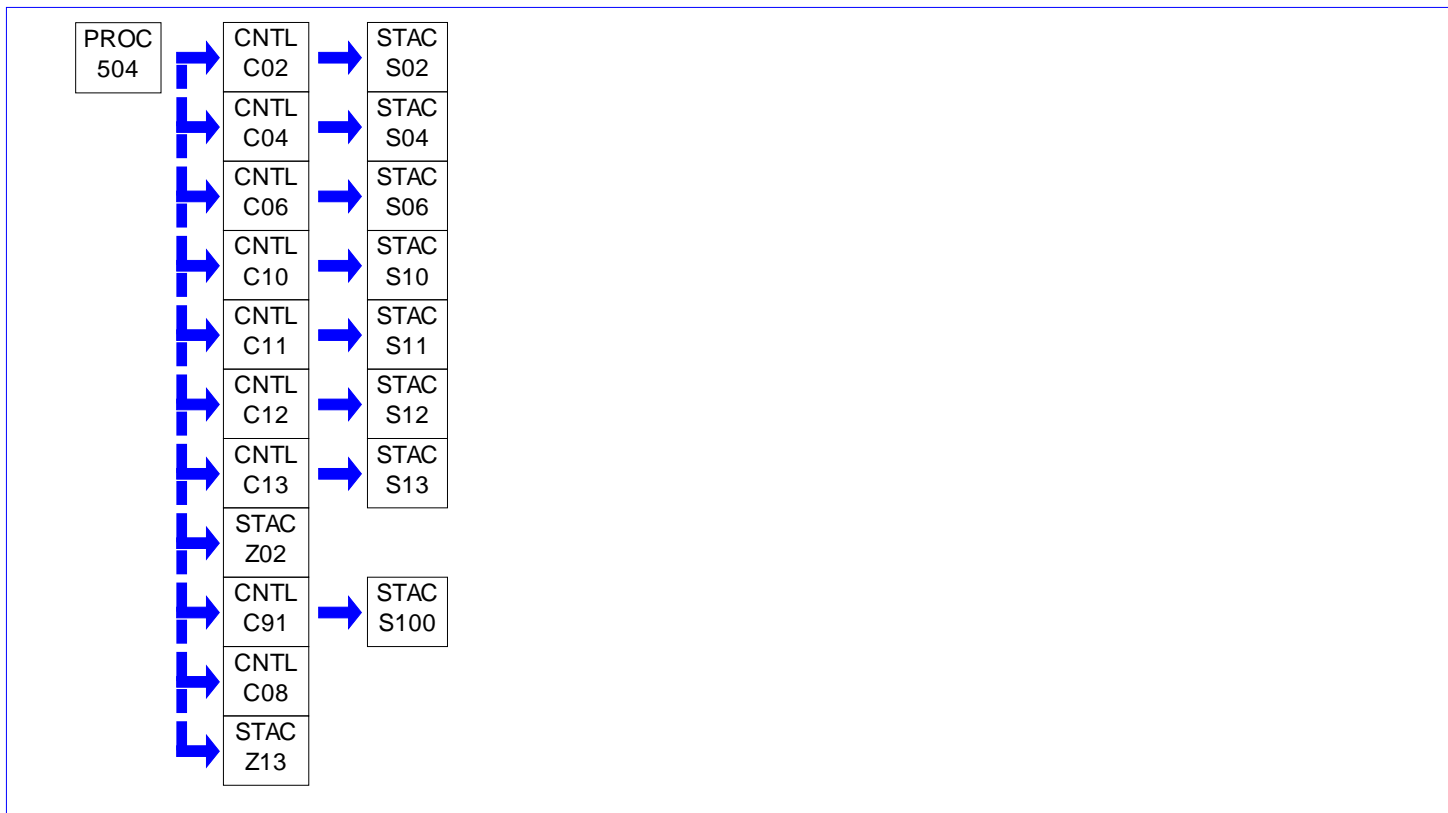
**I. RESTRICTIONS.****Emission Restriction(s).**

001 [25 Pa. Code §123.13]

Processes

No person shall permit the emission into the outdoor atmosphere of particulate matter from each of the above Fabric Collectors, at any time, in such a manner that the concentration of particulate matter in the effluent gas exceeds 0.01 grain per dry standard cubic foot.

II. TESTING REQUIREMENTS.

No additional testing requirements exist except as provided in other sections of this permit including Section B (Title V General Requirements) and/or Section E (Source Group Restrictions).

III. MONITORING REQUIREMENTS.

No additional monitoring requirements exist except as provided in other sections of this permit including Section B (Title V General Requirements) and/or Section E (Source Group Restrictions).



SECTION D. Source Level Requirements

IV. RECORDKEEPING REQUIREMENTS.

No additional record keeping requirements exist except as provided in other sections of this permit including Section B (Title V General Requirements) and/or Section E (Source Group Restrictions).

V. REPORTING REQUIREMENTS.

No additional reporting requirements exist except as provided in other sections of this permit including Section B (Title V General Requirements) and/or Section E (Source Group Restrictions).

VI. WORK PRACTICE REQUIREMENTS.

No additional work practice requirements exist except as provided in other sections of this permit including Section B (Title V General Requirements) and/or Section E (Source Group Restrictions).

VII. ADDITIONAL REQUIREMENTS.

No additional requirements exist except as provided in other sections of this permit including Section B (Title V General Requirements) and/or Section E (Source Group Restrictions).

***** Permit Shield in Effect. *****

**SECTION D. Source Level Requirements**

Source ID: 505

Source Name: GRINDING

Source Capacity/Throughput:

27.000 Tons/HR

CASTINGS

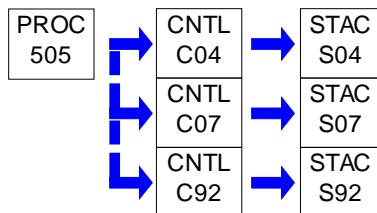
**I. RESTRICTIONS.****Emission Restriction(s).**

001 [25 Pa. Code §123.13]

Processes

[Additional authority for the following condition was derived from plan approval 36-05019D & G]

(1) No person shall permit the emissions into the outdoor atmosphere of particulate matter from the following fabric filters, in a manner, that the concentration of particulate matter in the effluent gas exceeds 0.01 grains per dry standard cubic foot.

#DC-450 (C92)

#DC-425 (C04)

(2) No person shall permit the emissions into the outdoor atmosphere of particulate matter from the following fabric filter, in a manner, that the concentration of particulate matter in the effluent gas exceeds 0.02 grains per dry standard cubic foot.

#DC-414 (C07)

II. TESTING REQUIREMENTS.

No additional testing requirements exist except as provided in other sections of this permit including Section B (Title V General Requirements).

III. MONITORING REQUIREMENTS.

No additional monitoring requirements exist except as provided in other sections of this permit including Section B (Title V General Requirements).

IV. RECORDKEEPING REQUIREMENTS.

No additional record keeping requirements exist except as provided in other sections of this permit including Section B (Title V General Requirements).

V. REPORTING REQUIREMENTS.

No additional reporting requirements exist except as provided in other sections of this permit including Section B (Title V General Requirements).

**SECTION D. Source Level Requirements****VI. WORK PRACTICE REQUIREMENTS.****# 002 [25 Pa. Code §127.441]****Operating permit terms and conditions.**

In order to assure compliance with the requirement of Condition #001 above, the permittee shall be required to perform the following:

- (1) Monitor and record the pressure drop across each of the above baghouses on a weekly basis. The permittee shall review each reading with the manufacturer's suggested pressure drop operating range for the baghouses. In the event the pressure drop readings are not within the manufacturer's recommended operating range, the permittee shall take corrective actions to return the operations of the baghouse to within the recommended operating range.
- (2) Each reading shall be entered in a logbook indicating the date and time the reading was taken, the name of the company representative taking the reading, the manufacturer's recommended operating range, and any corrective actions or maintenance performed. The logbook shall be maintained at the facility for a period of five (5) years and be made available to the Department upon request.

VII. ADDITIONAL REQUIREMENTS.

No additional requirements exist except as provided in other sections of this permit including Section B (Title V General Requirements).

***** Permit Shield in Effect. *****

**SECTION D. Source Level Requirements**

Source ID: 506

Source Name: DISA CASTING CLEANING

Source Capacity/Throughput: 150.000 Tons/HR IRON

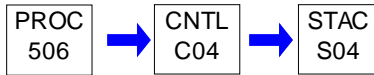
**I. RESTRICTIONS.****Emission Restriction(s).**

001 [25 Pa. Code §123.13]
Processes

No person shall permit the emissions into the outdoor atmosphere of particulate matter from the above fabric filter, in a manner, that the concentration of particulate matter in the effluent gas exceeds 0.01 grains per dry standard cubic foot.

II. TESTING REQUIREMENTS.

No additional testing requirements exist except as provided in other sections of this permit including Section B (Title V General Requirements).

III. MONITORING REQUIREMENTS.

No additional monitoring requirements exist except as provided in other sections of this permit including Section B (Title V General Requirements).

IV. RECORDKEEPING REQUIREMENTS.

No additional record keeping requirements exist except as provided in other sections of this permit including Section B (Title V General Requirements).

V. REPORTING REQUIREMENTS.

No additional reporting requirements exist except as provided in other sections of this permit including Section B (Title V General Requirements).

VI. WORK PRACTICE REQUIREMENTS.

002 [25 Pa. Code §127.441]
Operating permit terms and conditions.

In order to assure compliance with the requirement of Condition #001 above, the permittee shall be required to perform the following:

- (1) Monitor and record the pressure drop across the above baghouse on a weekly basis. The permittee shall review each reading with the manufacturer's suggested pressure drop operating range for the baghouse. In the event the pressure drop readings are not within the manufacturer's recommended operating range, the permittee shall take corrective actions to return the operations of the baghouse to within the recommended operating range.
- (2) Each reading shall be entered in a logbook indicating the date and time the reading was taken, the name of the company representative taking the reading, the manufacturer's recommended operating range, and any corrective actions or maintenance performed. The logbook shall be maintained at the facility for a period of five (5) years and be made available to the Department upon request.

**SECTION D. Source Level Requirements****VII. ADDITIONAL REQUIREMENTS.**

No additional requirements exist except as provided in other sections of this permit including Section B (Title V General Requirements).

***** Permit Shield in Effect. *****

**SECTION D. Source Level Requirements**

Source ID: 601

Source Name: SAVELLI POURING/CASTING

Source Capacity/Throughput: 10.000 Tons/HR IRON

Conditions for this source occur in the following groups: GROUP 001
 GROUP 006
 GROUP 008

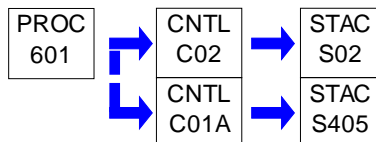
**I. RESTRICTIONS.****Emission Restriction(s).**

001 [25 Pa. Code §123.13]

Processes

No person shall permit the emissions into the outdoor atmosphere of particulate matter from the above Fabric Collectors, at any time, in such a manner that the concentration of particulate matter in the effluent gas exceeds 0.01 grain per dry standard cubic foot.

II. TESTING REQUIREMENTS.

No additional testing requirements exist except as provided in other sections of this permit including Section B (Title V General Requirements) and/or Section E (Source Group Restrictions).

III. MONITORING REQUIREMENTS.

No additional monitoring requirements exist except as provided in other sections of this permit including Section B (Title V General Requirements) and/or Section E (Source Group Restrictions).

IV. RECORDKEEPING REQUIREMENTS.

No additional record keeping requirements exist except as provided in other sections of this permit including Section B (Title V General Requirements) and/or Section E (Source Group Restrictions).

V. REPORTING REQUIREMENTS.

No additional reporting requirements exist except as provided in other sections of this permit including Section B (Title V General Requirements) and/or Section E (Source Group Restrictions).

VI. WORK PRACTICE REQUIREMENTS.

002 [25 Pa. Code §127.441]

Operating permit terms and conditions.

In order to assure compliance with the requirement of Condition #001 above, the permittee shall be required to perform the following:

(1) Monitor and record the pressure drop across each of the above baghouses on a weekly basis. The permittee shall review each reading with the manufacturer's suggested pressure drop operating range for the baghouses. In the event the pressure drop readings are not within the manufacturer's recommended operating range, the permittee shall take corrective actions to return the operations of the baghouse to within the recommended operating range.

**SECTION D. Source Level Requirements**

(2) Each reading shall be entered in a logbook indicating the date and time the reading was taken, the name of the company representative taking the reading, the manufacturer's recommended operating range, and any corrective actions or maintenance performed. The logbook shall be maintained at the facility for a period of five (5) years and be made available to the Department upon request.

VII. ADDITIONAL REQUIREMENTS.

No additional requirements exist except as provided in other sections of this permit including Section B (Title V General Requirements) and/or Section E (Source Group Restrictions).

***** Permit Shield in Effect. *****

**SECTION D. Source Level Requirements**

Source ID: 602

Source Name: SAVELLI CASTING/COOLING

Source Capacity/Throughput:

10.000 Tons/HR

CASTINGS

Conditions for this source occur in the following groups: GROUP 001

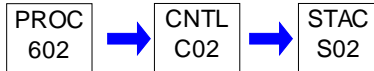
**I. RESTRICTIONS.****Emission Restriction(s).**

001 [25 Pa. Code §123.13]

Processes

No person shall permit the emissions into the outdoor atmosphere of particulate matter from the above Fabric Collector, at any time, in such a manner that the concentration of particulate matter in the effluent gas exceeds 0.01 grain per dry standard cubic foot.

II. TESTING REQUIREMENTS.

No additional testing requirements exist except as provided in other sections of this permit including Section B (Title V General Requirements) and/or Section E (Source Group Restrictions).

III. MONITORING REQUIREMENTS.

No additional monitoring requirements exist except as provided in other sections of this permit including Section B (Title V General Requirements) and/or Section E (Source Group Restrictions).

IV. RECORDKEEPING REQUIREMENTS.

No additional record keeping requirements exist except as provided in other sections of this permit including Section B (Title V General Requirements) and/or Section E (Source Group Restrictions).

V. REPORTING REQUIREMENTS.

No additional reporting requirements exist except as provided in other sections of this permit including Section B (Title V General Requirements) and/or Section E (Source Group Restrictions).

VI. WORK PRACTICE REQUIREMENTS.

002 [25 Pa. Code §127.441]

Operating permit terms and conditions.

In order to assure compliance with the requirement of Condition #001 above, the permittee shall be required to perform the following:

(1) Monitor and record the pressure drop across the above baghouse on a weekly basis. The permittee shall review each reading with the manufacturer's suggested pressure drop operating range for the baghouse. In the event the pressure drop readings are not within the manufacturer's recommended operating range, the permittee shall take corrective actions to return the operations of the baghouse to within the recommended operating range.

(2) Each reading shall be entered in a logbook indicating the date and time the reading was taken, the name of the company representative taking the reading, the manufacturer's recommended operating range, and any corrective actions or maintenance performed. The logbook shall be maintained at the facility for a period of five (5) years and be made available

**SECTION D. Source Level Requirements**

to the Department upon request.

VII. ADDITIONAL REQUIREMENTS.

No additional requirements exist except as provided in other sections of this permit including Section B (Title V General Requirements) and/or Section E (Source Group Restrictions).

***** Permit Shield in Effect. *****

**SECTION D. Source Level Requirements**

Source ID: 603

Source Name: SAVELLI CASTING/SHAKEOUT

Source Capacity/Throughput:

10.000 Tons/HR

CASTINGS

Conditions for this source occur in the following groups: GROUP 001
 GROUP 006
 GROUP 008

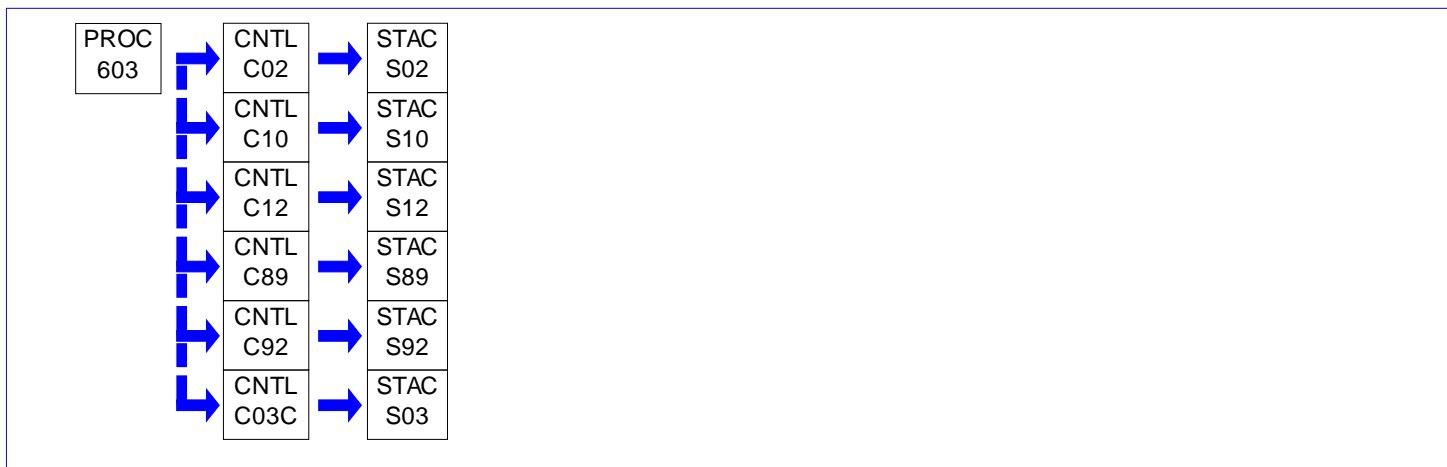
**I. RESTRICTIONS.****Emission Restriction(s).**

001 [25 Pa. Code §123.13]

Processes

No person shall permit the emissions into the outdoor atmosphere of particulate matter from the above Fabric Collector, at any time, in such a manner that the concentration of particulate matter in the effluent gas exceeds 0.01 grain per dry standard cubic foot.

II. TESTING REQUIREMENTS.

No additional testing requirements exist except as provided in other sections of this permit including Section B (Title V General Requirements) and/or Section E (Source Group Restrictions).

III. MONITORING REQUIREMENTS.

No additional monitoring requirements exist except as provided in other sections of this permit including Section B (Title V General Requirements) and/or Section E (Source Group Restrictions).

IV. RECORDKEEPING REQUIREMENTS.

No additional record keeping requirements exist except as provided in other sections of this permit including Section B (Title V General Requirements) and/or Section E (Source Group Restrictions).

V. REPORTING REQUIREMENTS.

No additional reporting requirements exist except as provided in other sections of this permit including Section B (Title V General Requirements) and/or Section E (Source Group Restrictions).

**SECTION D. Source Level Requirements****VI. WORK PRACTICE REQUIREMENTS.****# 002 [25 Pa. Code §127.441]****Operating permit terms and conditions.**

In order to assure compliance with the requirement of Condition #001 above, the permittee shall be required to perform the following:

- (1) Monitor and record the pressure drop across the above baghouse on a weekly basis. The permittee shall review each reading with the manufacturer's suggested pressure drop operating range for the baghouse. In the event the pressure drop readings are not within the manufacturer's recommended operating range, the permittee shall take corrective actions to return the operations of the baghouse to within the recommended operating range.
- (2) Each reading shall be entered in a logbook indicating the date and time the reading was taken, the name of the company representative taking the reading, the manufacturer's recommended operating range, and any corrective actions or maintenance performed. The logbook shall be maintained at the facility for a period of five (5) years and be made available to the Department upon request.

VII. ADDITIONAL REQUIREMENTS.

No additional requirements exist except as provided in other sections of this permit including Section B (Title V General Requirements) and/or Section E (Source Group Restrictions).

***** Permit Shield in Effect. *****

**SECTION E. Source Group Restrictions.**

Group Name: GROUP 001

Group Description: VOC Capped Sources

Sources included in this group

ID	Name
501	DISA POURING/CASTING
502	DISA CASTING/COOLING
503	DISA CASTING/SHAKEOUT
601	SAVELLI POURING/CASTING
602	SAVELLI CASTING/COOLING
603	SAVELLI CASTING/SHAKEOUT

I. RESTRICTIONS.**Emission Restriction(s).**

001 [25 Pa. Code §127.441]

Operating permit terms and conditions.

(a) The combined VOC emissions from the above sources shall not exceed 117.7 tons per year, based on any consecutive 12-month rolling period.

(b) In order to assure compliance with paragraph (a) above, the permittee shall be required to do the following:

(1) Limit the combined VOC emission rate for the above sources to 0.96 lb of VOC per ton of metal poured.

(2) Limit the throughput capacities of metal processed to the following:

(i) Source ID #501, Pouring/Casting - 36 TPH

(ii) Source ID #502, Casting/Cooling - 36 TPH

(iii) Source ID #503, Shakeout - 36 TPH

(iv) Source ID #601, Pouring/Casting - 10 TPH

(v) Source ID #602, Casting/Cooling - 10 TPH

(vi) Source ID #603, Shakeout - 10 TPH

(c) The permittee shall limit the emissions into the outdoor atmosphere of particulate matter from the following fabric collectors in a manner that the concentration of particulate matter in the effluent gas does not exceed 0.01 gr/dscf:

(1) Fabric Collector DC410

(2) Fabric Collector DC420

(3) Fabric Collector DC427

(4) Fabric Collector DC428

II. TESTING REQUIREMENTS.

No additional testing requirements exist except as provided in other sections of this permit including Section B (Title V General Requirements).

III. MONITORING REQUIREMENTS.

No additional monitoring requirements exist except as provided in other sections of this permit including Section B (Title V General Requirements).

IV. RECORDKEEPING REQUIREMENTS.

No additional record keeping requirements exist except as provided in other sections of this permit including Section B (Title V General Requirements).

**SECTION E. Source Group Restrictions.****V. REPORTING REQUIREMENTS.**

No additional reporting requirements exist except as provided in other sections of this permit including Section B (Title V General Requirements).

VI. WORK PRACTICE REQUIREMENTS.

No additional work practice requirements exist except as provided in other sections of this permit including Section B (Title V General Requirements).

VII. ADDITIONAL REQUIREMENTS.

No additional requirements exist except as provided in other sections of this permit including Section B (Title V General Requirements).

***** Permit Shield in Effect. *****

**SECTION E. Source Group Restrictions.**

Group Name: GROUP 002

Group Description: Larger grain loading sources (0.04 gr/dscf)

Sources included in this group

ID	Name
130	HOT DIP GALVANIZING #4 KETTLE
131	HOT DIP GALVANIZING #5 KETTLE
189	(2) SCRAP PREHEATERS
305	N.F. CLEANING

I. RESTRICTIONS.**Emission Restriction(s).**

001 [25 Pa. Code §123.13]

Processes

No person shall permit the emission into the outdoor atmosphere of particulate matter from the above sources, at any time, in such a manner that the concentration of particulate matter in the effluent gas exceeds 0.04 grain per dry standard cubic foot.

II. TESTING REQUIREMENTS.

No additional testing requirements exist except as provided in other sections of this permit including Section B (Title V General Requirements).

III. MONITORING REQUIREMENTS.

No additional monitoring requirements exist except as provided in other sections of this permit including Section B (Title V General Requirements).

IV. RECORDKEEPING REQUIREMENTS.

No additional record keeping requirements exist except as provided in other sections of this permit including Section B (Title V General Requirements).

V. REPORTING REQUIREMENTS.

No additional reporting requirements exist except as provided in other sections of this permit including Section B (Title V General Requirements).

VI. WORK PRACTICE REQUIREMENTS.

002 [25 Pa. Code §127.441]

Operating permit terms and conditions.

In order to assure compliance with the requirement of Condition #001 above, the permittee shall be required to perform the following:

(1) Monitor and record the pressure drop across the above baghouse on a weekly basis. The permittee shall review each reading with the manufacturer's suggested pressure drop operating range for the baghouse. In the event the pressure drop readings are not within the manufacturer's recommended operating range, the permittee shall take corrective actions to return the operations of the baghouse to within the recommended operating range.

(2) Each reading shall be entered in a logbook indicating the date and time the reading was taken, the name of the company representative taking the reading, the manufacturer's recommended operating range, and any corrective actions or maintenance performed. The logbook shall be maintained at the facility for a period of five (5) years and be made available to the Department upon request.

**SECTION E. Source Group Restrictions.****VII. ADDITIONAL REQUIREMENTS.**

No additional requirements exist except as provided in other sections of this permit including Section B (Title V General Requirements).

***** Permit Shield in Effect. *****

**SECTION E. Source Group Restrictions.**

Group Name: GROUP 003

Group Description: CAM Sources controlled by fabric filters

Sources included in this group

ID	Name
188	MELT OPERATIONS
501	DISA POURING/CASTING
502	DISA CASTING/COOLING
503	DISA CASTING/SHAKEOUT
504	DISA SAND SYSTEM

I. RESTRICTIONS.

No additional requirements exist except as provided in other sections of this permit including Section B (Title V General Requirements).

II. TESTING REQUIREMENTS.

No additional testing requirements exist except as provided in other sections of this permit including Section B (Title V General Requirements).

III. MONITORING REQUIREMENTS.**# 001 [25 Pa. Code §127.441]****Operating permit terms and conditions.**

[Additional authority for the following Compliance Assurance Monitoring conditions are derived from 40 CFR Part 64, Sections 64.3 & 64.6]

- (a) The permittee shall use the pressure differential across the above fabric collectors to obtain data and monitor the emission control equipment performance.
- (b) The permittee shall operate and maintain manometers to measure the pressure differential across each of the fabric collectors associated with the above sources.
- (c) The permittee shall monitor the pressure differential across each of the above fabric collectors once per day while the source(s) and respective fabric collectors are operating.
- (d) The permittee shall average the daily pressure differential values on a weekly basis for the purpose of determining an excursion.

IV. RECORDKEEPING REQUIREMENTS.**# 002 [25 Pa. Code §127.441]****Operating permit terms and conditions.**

[Additional authority for the following Compliance Assurance Monitoring (CAM) conditions are derived from 40 CFR Part 64, Section 64.9 and 40 CFR Part 70, Section 70.6(a)(3)(ii)(B)]

- (a) The permittee shall maintain records of the following information:
 - (1) Daily readings of the pressure differential across each of above fabric collectors, as well as the weekly average.
 - (2) The permittee shall record all excursions and corrective actions taken in response to an excursion and the time elapsed until the corrective actions have been taken.
 - (3) The permittee shall record all inspections, repairs and maintenance performed on the monitoring equipment.
 - (4) The permittee shall maintain records of all monitoring equipment down time incidents (other than down time associated with accuracy checks or calibration checks). The permittee shall also record the dates, times and durations, possible causes and corrective actions taken for the incidents.

**SECTION E. Source Group Restrictions.**

(b) The permittee shall keep all records for a period of five (5) years and make the records available to the Department upon request.

V. REPORTING REQUIREMENTS.**# 003 [25 Pa. Code §127.441]****Operating permit terms and conditions.**

[Additional authority for the following Compliance Assurance Monitoring (CAM) conditions are derived from 40 CFR Part 64, Section 64.9 and 40 CFR Part 70, Section 70.6(a)(3)(iii)(A)]

(a) The permittee shall report all excursions and corrective actions taken, the dates, times, durations and possible causes, every six (6) months.

(b) The permittee shall report all monitoring equipment down time incidents (other than down time associated with accuracy checks or calibration checks), their dates, times and durations, possible causes and corrective actions taken, every six (6) months.

VI. WORK PRACTICE REQUIREMENTS.**# 004 [25 Pa. Code §127.441]****Operating permit terms and conditions.**

[Additional authority for the following Compliance Assurance Monitoring (CAM) conditions are derived from 40 CFR Part 64, Sections 64.3 & 64.6]

(a) A fabric filter pressure drop range of 1.0 to 9.0 inches of water shall be used to determine appropriate operation of the fabric collectors. Excursions shall be determined per paragraph (b) below, except that readings shall be excluded that occur during:

- (1) The initial break-in period for new collector bags.
- (2) The first 15 minutes during the initial start-up of the source.

(b) A departure from the pressure differential ranges specified in paragraph (a), above, based on the average of the daily pressure differential values, on a weekly basis, shall be defined as an excursion. Failure to perform a daily pressure differential monitoring shall also be defined as an excursion.

(c) The permittee shall operate and maintain manometers to measure the pressure differential across each of the above fabric collectors. The manometers shall measure the pressure differential of the inlet and outlet of the respective fabric collector.

(d) The permittee shall inspect each manometer on a monthly basis to ensure that the gauge returns to zero when the system is off. The permittee shall check the manometer a minimum of once per year to ensure measurement accuracy within 10%. A manometer that is not operating with a measurement accuracy within 10% shall be replaced with a new calibrated manometer. Results of the annual manometer measurement accuracy checks shall be retained on site for a minimum of five (5) years and be made available to the Department upon request.

(e) The permittee, at a minimum, shall inspect the pressure differential tubing for blockage on a quarterly basis

(f) The permittee shall maintain spare manometers and related parts on site for routine repairs/replacement.

(g) The permittee shall maintain an ample supply of spare (replacement) bags for the fabric collectors on site.

005 [25 Pa. Code §127.441]**Operating permit terms and conditions.**

The permittee shall operate each fabric collector at all times when its respective source(s) is operating.

**SECTION E. Source Group Restrictions.****VII. ADDITIONAL REQUIREMENTS.****# 006 [25 Pa. Code §127.441]****Operating permit terms and conditions.**

[Additional authority for the following Compliance Assurance Monitoring (CAM) conditions are derived from 40 CFR Part 64, Sections 64.8 & 64.9]

(a) The permittee shall develop and implement a quality improvement plan (QIP) as expeditiously as practicable if any of the following occurs:

(1) Six excursions per source occurs in a six-month reporting period.

(2) The Department determines after review of all reported information that the permittee has not responded acceptably to an excursion.

(b) The QIP should be developed within 60 days and the permittee shall provide a copy of the QIP to the Department. Furthermore, the permittee shall notify the Department if the period for completing the improvements contained in the QIP exceeds 180 days from the date on which the need to implement the QIP was determined.

(c) The permittee shall record actions taken to implement the QIP during a reporting period and all related actions including, but not limited to inspections, repairs and maintenance performed on the monitoring equipment.

(d) The QIP shall include procedures for evaluating the control performance problems. Based on the results of the evaluation procedures, the permittee shall modify the QIP, and provide a copy to the Department, to include procedures for conducting more frequent or improved monitoring in conjunction with one or more of the following:

(1) Improved preventive maintenance practices.

(2) Process operation changes.

(3) Appropriate improvements to control methods.

(4) Other steps appropriate to correct performance.

(e) Following implementation of a QIP, the Department will require reasonable revisions to the QIP if the plan has failed to either:

(1) Address the cause of the control device performance problem.

(2) Provide adequate procedures for correcting control device performance problems in as expeditiously as practicable in accordance with good air pollution control practices for minimizing emissions.

(f) Implementation of a QIP shall not excuse the owner or operator of a source from compliance with any existing emission limitation or standard or any existing monitoring, testing, reporting or recordkeeping requirement that may apply under any federal, state, or local laws or any other applicable requirements under the Clean Air Act.

***** Permit Shield in Effect. *****

**SECTION E. Source Group Restrictions.**

Group Name: GROUP 004

Group Description: 40 CFR Part 63, Subpart ZZZZZ Requirements

Sources included in this group

ID	Name
188	MELT OPERATIONS

I. RESTRICTIONS.

No additional requirements exist except as provided in other sections of this permit including Section B (Title V General Requirements).

II. TESTING REQUIREMENTS.

No additional testing requirements exist except as provided in other sections of this permit including Section B (Title V General Requirements).

III. MONITORING REQUIREMENTS.

No additional monitoring requirements exist except as provided in other sections of this permit including Section B (Title V General Requirements).

IV. RECORDKEEPING REQUIREMENTS.

No additional record keeping requirements exist except as provided in other sections of this permit including Section B (Title V General Requirements).

V. REPORTING REQUIREMENTS.**# 001 [40 CFR Part 63 NESHAPS for Source Categories §40 CFR 63.10880]****Subpart ZZZZZ - National Emission Standards for Hazardous Air Pollutants for Iron and Steel Foundries Area Sources Am I subject to this subpart?**

§63.10880 Am I subject to this subpart?

(a) You are subject to this subpart if you own or operate an iron and steel foundry that is an area source of hazardous air pollutant (HAP) emissions.

(b) This subpart applies to each new or existing affected source. The affected source is each iron and steel foundry.

(1) An affected source is existing if you commenced construction or reconstruction of the affected source before September 17, 2007.

(2) [N/A - SOURCES ARE EXISTING]

(c) On and after January 2, 2008, if your iron and steel foundry becomes a major source as defined in §63.2, you must meet the requirements of 40 CFR part 63, Subpart EEEEE.

(d) [N/A - NOT A RESEARCH AND DEVELOPMENT FACILITY]

(e) You are exempt from the obligation to obtain a permit under 40 CFR part 70 or 40 CFR part 71, provided you are not otherwise required by law to obtain a permit under 40 CFR 70.3(a) or 40 CFR 71.3(a). Notwithstanding the previous sentence, you must continue to comply with the provisions of this subpart.

(f) [ANVIL INTERNATIONAL SUBMITTED AN INITIAL NOTIFICATION OF APPLICABILITY ON APRIL 24, 2008. THE NOTIFICATION IDENTIFIES ANVIL INTERNATIONAL AS AN EXISTING LARGE IRON AND STEEL FOUNDRY WITH GREATER THAN 20,000 TONS OF METAL MELT PRODUCTION FOR THE CALENDAR YEAR 2008]

(g) [N/A - SOURCES ARE EXISTING]

**SECTION E. Source Group Restrictions.**

§63.10881 What are my compliance dates?

(a) If you own or operate an existing affected source, you must achieve compliance with the applicable provisions of this subpart by the dates in paragraphs (a)(1) through (3) of this section.

(1) Not later than January 2, 2009 for the pollution prevention management practices for metallic scrap in §63.10885(a) and binder formulations in §63.10886.

(2) Not later than January 4, 2010 for the pollution prevention management practices for mercury in §63.10885(b).

(3) Except as provided in paragraph (d) of this section, not later than 2 years after the date of your large foundry's notification of the initial determination required in §63.10880(f) for the standards and management practices in §63.10895.

(b) [N/A - SOURCES ARE EXISTING]

(c) [N/A - SOURCES ARE EXISTING]

(d) Following the initial determination for an existing affected source required in §63.10880(f),

(1) [N/A - FACILITY IS CLASSIFIED AS A LARGE FOUNDRY]

(2) If your facility is initially classified as a large foundry (or your small foundry subsequently becomes a large foundry), you must comply with the requirements for a large foundry for at least 3 years before reclassifying your facility as a small foundry, even if your annual metal melt production falls below 20,000 tons. After 3 years, you may reclassify your facility as a small foundry provided your annual metal melt production for the preceding calendar year was 20,000 tons or less. If you reclassify your large foundry as a small foundry, you must submit a notification of reclassification to the Administrator within 30 days and comply with the requirements for a small foundry no later than the date you notify the Administrator of the reclassification. If the annual metal melt production exceeds 20,000 tons during a subsequent year, you must submit a notification of reclassification to the Administrator within 30 days and comply with the requirements for a large foundry no later than the date you notify the Administrator of the reclassification.

(e) [N/A - SOURCES ARE EXISTING]

§63.10885 What are my management practices for metallic scrap and mercury switches?

(a) Metallic scrap management program. For each segregated metallic scrap storage area, bin or pile, you must comply with the materials acquisition requirements in paragraph (a)(1) or (2) of this section. You must keep a copy of the material specifications onsite and readily available to all personnel with material acquisition duties, and provide a copy to each of your scrap providers. You may have certain scrap subject to paragraph (a)(1) of this section and other scrap subject to paragraph (a)(2) of this section at your facility provided the metallic scrap remains segregated until charge make-up.

(1) Restricted metallic scrap. You must prepare and operate at all times according to written material specifications for the purchase and use of only metal ingots, pig iron, slitter, or other materials that do not include post-consumer automotive body scrap, post-consumer engine blocks, post-consumer oil filters, oily turnings, lead components, chlorinated plastics, or free liquids. For the purpose of this subpart, "free liquids" is defined as material that fails the paint filter test by EPA Method 9095B, "Paint Filter Liquids Test" (revision 2), November 2004 (incorporated by reference see §63.14). The requirements for no free liquids do not apply if the owner or operator can demonstrate that the free liquid is water that resulted from scrap exposure to rain.

(2) General iron and steel scrap. You must prepare and operate at all times according to written material specifications for the purchase and use of only iron and steel scrap that has been depleted (to the extent practicable) of organics and HAP metals in the charge materials used by the iron and steel foundry. The materials specifications must include at minimum the information specified in paragraph (a)(2)(i) or (ii) of this section.

(i) Except as provided in paragraph (a)(2)(ii) of this section, specifications for metallic scrap materials charged to a scrap preheater or metal melting furnace to be depleted (to the extent practicable) of the presence of used oil filters, chlorinated plastic parts, accessible lead-containing components (such as batteries and wheel weights), and a program to ensure the

**SECTION E. Source Group Restrictions.**

scrap materials are drained of free liquids.

(ii) For scrap charged to a cupola metal melting furnace that is equipped with an afterburner, specifications for metallic scrap materials to be depleted (to the extent practicable) of the presence of chlorinated plastics, accessible lead-containing components (such as batteries and wheel weights), and a program to ensure the scrap materials are drained of free liquids.

(b) Mercury requirements. For scrap containing motor vehicle scrap, you must procure the scrap pursuant to one of the compliance options in paragraphs (b)(1), (2), or (3) of this section for each scrap provider, contract, or shipment. For scrap that does not contain motor vehicle scrap, you must procure the scrap pursuant to the requirements in paragraph (b)(4) of this section for each scrap provider, contract, or shipment. You may have one scrap provider, contract, or shipment subject to one compliance provision and others subject to another compliance provision [NOTE: FACILITY CURRENTLY COMPLIES WITH OPTION #4 OF THIS SECTION BY MAINTAINING RECORDS OF DOCUMENTATION THAT THE PROCURED SCRAP DOES NOT CONTAIN MOTOR VEHICLE SCRAP].

(1) Site specific plan for mercury switches. You must comply with the requirements in paragraphs (b)(1)(i) through (v) of this section

(i) You must include a requirement in your scrap specifications for removal of mercury switches from vehicle bodies used to make the scrap.

(ii) You must prepare and operate according to a plan demonstrating how your facility will implement the scrap specification in paragraph (b)(1)(i) of this section for removal of mercury switches. You must submit the plan to the Administrator for approval. You must operate according to the plan as submitted during the review and approval process, operate according to the approved plan at all times after approval, and address any deficiency identified by the Administrator or delegated authority within 60 days following disapproval of a plan. You may request approval to revise the plan and may operate according to the revised plan unless and until the revision is disapproved by the Administrator or delegated authority. The Administrator or delegated authority may change the approval status of the plan upon 90-days written notice based upon the semiannual report or other information. The plan must include:

(A) A means of communicating to scrap purchasers and scrap providers the need to obtain or provide motor vehicle scrap from which mercury switches have been removed and the need to ensure the proper management of the mercury switches removed from the scrap as required under the rules implementing subtitle C of the Resource Conservation and Recovery Act (RCRA) (40 CFR parts 261 through 265 and 268). The plan must include documentation of direction to appropriate staff to communicate to suppliers throughout the scrap supply chain the need to promote the removal of mercury switches from end-of-life vehicles. Upon the request of the Administrator or delegated authority, you must provide examples of materials that are used for outreach to suppliers, such as letters, contract language, policies for purchasing agents, and scrap inspection protocols;

(B) Provisions for obtaining assurance from scrap providers motor vehicle scrap provided to the facility meet the scrap specification;

(C) Provisions for periodic inspections or other means of corroboration to ensure that scrap providers and dismantlers are implementing appropriate steps to minimize the presence of mercury switches in motor vehicle scrap and that the mercury switches removed are being properly managed, including the minimum frequency such means of corroboration will be implemented; and

(D) Provisions for taking corrective actions (i.e., actions resulting in scrap providers removing a higher percentage of mercury switches or other mercury-containing components) if needed, based on the results of procedures implemented in paragraph (b)(1)(ii)(C) of this section).

(iii) You must require each motor vehicle scrap provider to provide an estimate of the number of mercury switches removed from motor vehicle scrap sent to the facility during the previous year and the basis for the estimate. The Administrator may request documentation or additional information at any time.

(iv) You must establish a goal for each scrap supplier to remove at least 80 percent of the mercury switches. Although a site-specific plan approved under paragraph (b)(1) of this section may require only the removal of convenience light switch

**SECTION E. Source Group Restrictions.**

mechanisms, the Administrator will credit all documented and verifiable mercury-containing components removed from motor vehicle scrap (such as sensors in anti-locking brake systems, security systems, active ride control, and other applications) when evaluating progress towards the 80 percent goal.

(v) For each scrap provider, you must submit semiannual progress reports to the Administrator that provide the number of mercury switches removed or the weight of mercury recovered from the switches, the estimated number of vehicles processed, an estimate of the percent of mercury switches removed, and certification that the removed mercury switches were recycled at RCRA-permitted facilities or otherwise properly managed pursuant to RCRA subtitle C regulations referenced in paragraph (b)(1)(ii)(A) of this section. This information can be submitted in aggregate form and does not have to be submitted for each shipment. The Administrator may change the approval status of a site-specific plan following 90-days notice based on the progress reports or other information.

(2) Option for approved mercury programs. You must certify in your notification of compliance status that you participate in and purchase motor vehicle scrap only from scrap providers who participate in a program for removal of mercury switches that has been approved by the Administrator based on the criteria in paragraphs (b)(2)(i) through (iii) of this section. If you purchase motor vehicle scrap from a broker, you must certify that all scrap received from that broker was obtained from other scrap providers who participate in a program for the removal of mercury switches that has been approved by the Administrator based on the criteria in paragraphs (b)(2)(i) through (iii) of this section. The National Mercury Switch Recovery Program and the State of Maine Mercury Switch Removal Program are EPA-approved programs under paragraph (b)(2) of this section unless and until the Administrator disapproves the program (in part or in whole) under paragraph (b)(2)(iii) of this section.

(i) The program includes outreach that informs the dismantlers of the need for removal of mercury switches and provides training and guidance for removing mercury switches;

(ii) The program has a goal to remove at least 80 percent of mercury switches from motor vehicle scrap the scrap provider processes. Although a program approved under paragraph (b)(2) of this section may require only the removal of convenience light switch mechanisms, the Administrator will credit all documented and verifiable mercury-containing components removed from motor vehicle scrap (such as sensors in anti-locking brake systems, security systems, active ride control, and other applications) when evaluating progress towards the 80 percent goal; and

(iii) The program sponsor agrees to submit progress reports to the Administrator no less frequently than once every year that provide the number of mercury switches removed or the weight of mercury recovered from the switches, the estimated number of vehicles processed, an estimate of the percent of mercury switches recovered, and certification that the recovered mercury switches were recycled at facilities with permits as required under the rules implementing subtitle C of RCRA (40 CFR parts 261 through 265 and 268). The progress reports must be based on a database that includes data for each program participant; however, data may be aggregated at the State level for progress reports that will be publicly available. The Administrator may change the approval status of a program or portion of a program (e.g., at the State level) following 90-days notice based on the progress reports or on other information.

(iv) You must develop and maintain onsite a plan demonstrating the manner through which your facility is participating in the EPA-approved program.

(A) The plan must include facility-specific implementation elements, corporate-wide policies, and/or efforts coordinated by a trade association as appropriate for each facility.

(B) You must provide in the plan documentation of direction to appropriate staff to communicate to suppliers throughout the scrap supply chain the need to promote the removal of mercury switches from end-of-life vehicles. Upon the request of the Administrator or delegated authority, you must provide examples of materials that are used for outreach to suppliers, such as letters, contract language, policies for purchasing agents, and scrap inspection protocols.

(C) You must conduct periodic inspections or other means of corroboration to ensure that scrap providers are aware of the need for and are implementing appropriate steps to minimize the presence of mercury in scrap from end-of-life vehicles.

(3) Option for specialty metal scrap. You must certify in your notification of compliance status and maintain records of documentation that the only materials from motor vehicles in the scrap are materials recovered for their specialty alloy (including, but not limited to, chromium, nickel, molybdenum, or other alloys) content (such as certain exhaust systems)

**SECTION E. Source Group Restrictions.**

and, based on the nature of the scrap and purchase specifications, that the type of scrap is not reasonably expected to contain mercury switches.

(4) Scrap that does not contain motor vehicle scrap. For scrap not subject to the requirements in paragraphs (b)(1) through (3) of this section, you must certify in your notification of compliance status and maintain records of documentation that this scrap does not contain motor vehicle scrap.

§63.10886 What are my management practices for binder formulations?

For each furfuryl alcohol warm box mold or core making line at a new or existing iron and steel foundry, you must use a binder chemical formulation that does not use methanol as a specific ingredient of the catalyst formulation. This requirement does not apply to the resin portion of the binder system.

§63.10890 - [N/A - FACILITY IS CLASSIFIED AS A LARGE FACILITY]

Requirements for New and Existing Affected Sources Classified as Large Iron and Steel Foundries

§63.10895 What are my standards and management practices?

(a) If you own or operate an affected source that is a large foundry as defined in §63.10906, you must comply with the pollution prevention management practices in §§63.10885 and 63.10886, the requirements in paragraphs (b) through (e) of this section, and the requirements in §§63.10896 through 63.10900.

(b) You must operate a capture and collection system for each metal melting furnace at a new or existing iron and steel foundry unless that furnace is specifically uncontrolled as part of an emissions averaging group. Each capture and collection system must meet accepted engineering standards, such as those published by the American Conference of Governmental Industrial Hygienists.

(c) You must not discharge to the atmosphere emissions from any metal melting furnace or group of all metal melting furnaces that exceed the applicable limit in paragraph (c)(1) or (2) of this section. When an alternative emissions limit is provided for a given emissions source, you are not restricted in the selection of which applicable alternative emissions limit is used to demonstrate compliance.

(1) For an existing iron and steel foundry, 0.8 pounds of particulate matter (PM) per ton of metal charged or 0.06 pounds of total metal HAP per ton of metal charged.

(2) [N/A - FACILITY IS EXISTING]

(d) [N/A - SOURCES ARE EXISTING]

(e) If you own or operate a new or existing iron and steel foundry, you must not discharge to the atmosphere fugitive emissions from foundry operations that exhibit opacity greater than 20 percent (6-minute average), except for one 6-minute average per hour that does not exceed 30 percent.

§63.10896 What are my operation and maintenance requirements?

(a) You must prepare and operate at all times according to a written operation and maintenance (O&M) plan for each control device for an emissions source subject to a PM, metal HAP, or opacity emissions limit in §63.10895. You must maintain a copy of the O&M plan at the facility and make it available for review upon request. At a minimum, each plan must contain the following information:

(1) General facility and contact information;

(2) Positions responsible for inspecting, maintaining, and repairing emissions control devices which are used to comply with this subpart;

(3) Description of items, equipment, and conditions that will be inspected, including an inspection schedule for the items,

**SECTION E. Source Group Restrictions.**

equipment, and conditions. For baghouses that are equipped with bag leak detection systems, the O&M plan must include the site-specific monitoring plan required in §63.10897(d)(2).

(4) Identity and estimated quantity of the replacement parts that will be maintained in inventory; and

(5) [NA - FACILITY IS EXISTING]

(b) You may use any other O&M, preventative maintenance, or similar plan which addresses the requirements in paragraph (a)(1) through (5) of this section to demonstrate compliance with the requirements for an O&M plan.

§63.10897 What are my monitoring requirements?

(a) You must conduct an initial inspection of each PM control device for a metal melting furnace at an existing affected source. You must conduct each initial inspection no later than 60 days after your applicable compliance date for each installed control device which has been operated within 60 days of the compliance date. For an installed control device which has not operated within 60 days of the compliance date, you must conduct an initial inspection prior to startup of the control device. Following the initial inspections, you must perform periodic inspections and maintenance of each PM control device for a metal melting furnace at an existing affected source. You must perform the initial and periodic inspections according to the requirements in paragraphs (a)(1) through (4) of this section. You must record the results of each initial and periodic inspection and any maintenance action in the logbook required in §63.10899(b)(13).

(1) For the initial inspection of each baghouse, you must visually inspect the system ductwork and baghouse units for leaks. You must also inspect the inside of each baghouse for structural integrity and fabric filter condition. Following the initial inspections, you must inspect and maintain each baghouse according to the requirements in paragraphs (a)(1)(i) and (ii) of this section.

(i) You must conduct monthly visual inspections of the system ductwork for leaks.

(ii) You must conduct inspections of the interior of the baghouse for structural integrity and to determine the condition of the fabric filter every 6 months.

(2) [N/A - NO DRY ESPS]

(3) [N/A - NO WET ESPS]

(4) [N/A - NO WET SCRUBBERS]

(b) [N/A - NO WET SCRUBBERS]

(c) [N/A - NO ESPS]

(d) [N/A - NO BAG LEAK DETECTION SYSTEM INSTALLED]

(e) You must make monthly inspections of the equipment that is important to the performance of the total capture system (i.e., pressure sensors, dampers, and damper switches). This inspection must include observations of the physical appearance of the equipment (e.g., presence of holes in the ductwork or hoods, flow constrictions caused by dents or accumulated dust in the ductwork, and fan erosion). You must repair any defect or deficiency in the capture system as soon as practicable, but no later than 90 days. You must record the date and results of each inspection and the date of repair of any defect or deficiency.

(f) You must install, operate, and maintain each CPMS or other measurement device according to your O&M plan. You must record all information needed to document conformance with these requirements.

(g) In the event of an exceedance of an established emissions limitation (including an operating limit), you must restore operation of the emissions source (including the control device and associated capture system) to its normal or usual manner or operation as expeditiously as practicable in accordance with good air pollution control practices for minimizing emissions. The response shall include minimizing the period of any startup, shutdown or malfunction and taking any

**SECTION E. Source Group Restrictions.**

necessary corrective actions to restore normal operation and prevent the likely recurrence of the exceedance. You must record the date and time correction action was initiated, the correction action taken, and the date corrective action was completed.

(h) [NA - FACILITY DOES NOT USE EMISSION AVERAGING FOR COMPLIANCE PURPOSES]

§63.10898 What are my performance test requirements?

(a) [PERFORMANCE TESTING WAS CONDUCTED ON CONTROL DEVICE DC412 ON JUNE 15, 2011. FACILITY SUCCESSFULLY DEMONSTRATED COMPLIANCE WITH THE SUBPART ZZZZZ LIMIT FOR PARTICULATE MATTER EMISSIONS OF LESS THAN 0.8 LBS/TON OF METAL CHARGED].

(b) You must conduct subsequent performance tests to demonstrate compliance with all applicable PM or total metal HAP emissions limits in §63.10895(c) for a metal melting furnace or group of all metal melting furnaces no less frequently than every 5 years and each time you elect to change an operating limit or make a process change likely to increase HAP emissions.

(c) You must conduct each performance test according to the requirements in §63.7(e)(1), Table 1 to this subpart, and paragraphs (d) through (g) of this section.

(d) through (g) included by reference

(h) You must conduct each opacity test for fugitive emissions according to the requirements in §63.6(h)(5) and Table 1 to this subpart.

(i) You must conduct subsequent performance tests to demonstrate compliance with the opacity limit in §63.10895(e) no less frequently than every 6 months and each time you make a process change likely to increase fugitive emissions.

(j) In your performance test report, you must certify that the capture system operated normally during the performance test.

(k) [N/A - NO NEW AFFECTED SOURCES]

(l) [N/A - NO OPERATING LIMITS TO CHANGE]

§63.10899 What are my recordkeeping and reporting requirements?

(a) As required by §63.10(b)(1), you must maintain files of all information (including all reports and notifications) for at least 5 years following the date of each occurrence, measurement, maintenance, corrective action, report, or record. At a minimum, the most recent 2 years of data shall be retained on site. The remaining 3 years of data may be retained off site. Such files may be maintained on microfilm, on a computer, on computer floppy disks, on magnetic tape disks, or on microfiche.

(b) In addition to the records required by 40 CFR 63.10, you must keep records of the information specified in paragraphs (b)(1) through (13) of this section.

(1) You must keep records of your written materials specifications according to §63.10885(a) and records that demonstrate compliance with the requirements for restricted metallic scrap in §63.10885(a)(1) and/or for the use of general scrap in §63.10885(a)(2) and for mercury in §63.10885(b)(1) through (3), as applicable. You must keep records documenting compliance with §63.10885(b)(4) for scrap that does not contain motor vehicle scrap.

(2) If you are subject to the requirements for a site-specific plan for mercury under §63.10885(b)(1), you must:

(i) Maintain records of the number of mercury switches removed or the weight of mercury recovered from the switches and properly managed, the estimated number of vehicles processed, and an estimate of the percent of mercury switches recovered; and

(ii) Submit semiannual reports of the number of mercury switches removed or the weight of mercury recovered from the

**SECTION E. Source Group Restrictions.**

switches and properly managed, the estimated number of vehicles processed, an estimate of the percent of mercury switches recovered, and a certification that the recovered mercury switches were recycled at RCRA-permitted facilities. The semiannual reports must include a certification that you have conducted periodic inspections or taken other means of corroboration as required under §63.10885(b)(1)(ii)(C). You must identify which option in §63.10885(b) applies to each scrap provider, contract, or shipment. You may include this information in the semiannual compliance reports required under paragraph (c) of this section.

(3) If you are subject to the option for approved mercury programs under §63.10885(b)(2), you must maintain records identifying each scrap provider and documenting the scrap provider's participation in an approved mercury switch removal program. If your scrap provider is a broker, you must maintain records identifying each of the broker's scrap suppliers and documenting the scrap supplier's participation in an approved mercury switch removal program.

(4) You must keep records to document use of any binder chemical formulation that does not contain methanol as a specific ingredient of the catalyst formulation for each furfuryl alcohol warm box mold or core making line as required by §63.10886. These records must be the Material Safety Data Sheet (provided that it contains appropriate information), a certified product data sheet, or a manufacturer's hazardous air pollutant data sheet.

(5) You must keep records of the annual quantity and composition of each HAP-containing chemical binder or coating material used to make molds and cores. These records must be copies of purchasing records, Material Safety Data Sheets, or other documentation that provide information on the binder or coating materials used.

(6) You must keep records of monthly metal melt production for each calendar year.

(7) You must keep a copy of the operation and maintenance plan as required by §63.10896(a) and records that demonstrate compliance with plan requirements.

(8) [NA - FACILITY DOES NOT USE EMISSION AVERAGING FOR COMPLIANCE PURPOSES]

(9) [N/A - NO BAG LEAK DETECTION SYSTEM]

(10) you must keep records of capture system inspections and repairs as required by §63.10897(e).

(11) You must keep records demonstrating conformance with your specifications for the operation of CPMS as required by §63.10897(f).

(12) You must keep records of corrective action(s) for exceedances and excursions as required by §63.10897(g).

(13) You must record the results of each inspection and maintenance required by §63.10897(a) for PM control devices in a logbook (written or electronic format). You must keep the logbook onsite and make the logbook available to the Administrator upon request. You must keep records of the information specified in paragraphs (b)(13)(i) through (iii) of this section.

(i) The date and time of each recorded action for a fabric filter, the results of each inspection, and the results of any maintenance performed on the bag filters.

(ii) [N/A - NO ESPS]

(iii) [N/A - NO WET SCRUBBERS]

(c) You must submit semiannual compliance reports to the Administrator according to the requirements in §63.10(e). The reports must include, at a minimum, the following information as applicable:

(1) Summary information on the number, duration, and cause (including unknown cause, if applicable) of excursions or exceedances, as applicable, and the corrective action taken;

(2) Summary information on the number, duration, and cause (including unknown cause, if applicable) for monitor downtime incidents (other than downtime associated with zero and span or other calibration checks, if applicable); and

**SECTION E. Source Group Restrictions.**

(3) Summary information on any deviation from the pollution prevention management practices in §§63.10885 and 63.10886 and the operation and maintenance requirements §63.10896 and the corrective action taken.

(d) You must submit written notification to the Administrator of the initial classification of your new or existing affected source as a large iron and steel facility as required in §63.10880(f) and (g), as applicable, and for any subsequent reclassification as required in §63.10881(d) or (e), as applicable.

§63.10900 What parts of the General Provisions apply to my large foundry?

(a) If you own or operate a new or existing affected source that is classified as a large foundry, you must comply with the requirements of the General Provisions (40 CFR part 63, subpart A) according to Table 3 of this subpart.

(b) If you own or operator a new or existing affected source that is classified as a large foundry, your notification of compliance status required by §63.9(h) must include each applicable certification of compliance, signed by a responsible official, in Table 4 of this subpart.

OTHER REQUIREMENTS AND INFORMATION

§63.10905 Who implements and enforces this subpart?

(a) This subpart can be implemented and enforced by EPA or a delegated authority such as your State, local, or tribal agency. If the EPA Administrator has delegated authority to your State, local, or tribal agency, then that agency has the authority to implement and enforce this subpart. You should contact your EPA Regional Office to find out if implementation and enforcement of this subpart is delegated to your State, local, or tribal agency.

(b) In delegating implementation and enforcement authority of this subpart to a State, local, or tribal agency under 40 CFR part 63, subpart E, the authorities contained in paragraph (c) of this section are retained by the EPA Administrator and are not transferred to the State, local, or tribal agency.

(c) The authorities that cannot be delegated to State, local, or tribal agencies are specified in paragraphs (c)(1) through (6) of this section.

(1) Approval of an alternative non-opacity emissions standard under 40 CFR 63.6(g).

(2) Approval of an alternative opacity emissions standard under §63.6(h)(9).

(3) Approval of a major change to test methods under §63.7(e)(2)(ii) and (f). A "major change to test method" is defined in §63.90.

(4) Approval of a major change to monitoring under §63.8(f). A "major change to monitoring" under is defined in §63.90.

(5) Approval of a major change to recordkeeping and reporting under §63.10(f). A "major change to recordkeeping/reporting" is defined in §63.90.

(6) Approval of a local, State, or national mercury switch removal program under §63.10885(b)(2).

Regulatory Changes

Individual sources within this source group that are subject to 40 CFR Part 63 Subpart ZZZZZ shall comply with all applicable requirements of the Subpart. 40 CFR 63.13(a) requires submission of copies of all requests, reports and other communications to both the Department and the EPA. The EPA copies shall be forwarded to:

Director
Air Protection Division (3AP00)
U.S. EPA Region III
1650 Arch Street

**SECTION E. Source Group Restrictions.**

Philadelphia, PA 19103-2029

The Department copies shall be forwarded to:

Regional Air Program Manager
PA Department of Environmental Protection
909 Elmerton Avenue
Harrisburg, PA 17110-8200

In the event that the Federal Subpart that is the subject of this Source Group is revised, the permittee shall comply with the revised version of the subpart, and shall not be required to comply with any provisions in this permit designated as having the subpart as their authority, to the extent that such permit provisions would be inconsistent with the applicable provisions of the revised subpart.

VI. WORK PRACTICE REQUIREMENTS.

No additional work practice requirements exist except as provided in other sections of this permit including Section B (Title V General Requirements).

VII. ADDITIONAL REQUIREMENTS.

No additional requirements exist except as provided in other sections of this permit including Section B (Title V General Requirements).

***** Permit Shield in Effect. *****

**SECTION E. Source Group Restrictions.**

Group Name: GROUP 005

Group Description: 129.52d Requirements

Sources included in this group

ID	Name
191	SURFACE COATING DIP LINE

I. RESTRICTIONS.**Emission Restriction(s).****# 001 [25 Pa. Code §129.52d]****Control of VOC emissions from miscellaneous metal parts surface coating processes, miscellaneous plastic parts surf:**

(a) Applicability.

(1) This section applies to the owner and operator of a miscellaneous metal part surface coating process or miscellaneous plastic part surface coating process, or both, if the total actual VOC emissions from all miscellaneous metal part coating units and miscellaneous plastic part coating units, including related cleaning activities, at the facility are equal to or greater than 2.7 tons per 12-month rolling period, before consideration of controls.

(2) [NA - FACILITY EMITS > 2.7 TPY VOC]

(3) Compliance with the VOC emission limits and other requirements of this section assures compliance with the VOC emission limits and other requirements of § 129.52 (relating to surface coating processes) for the miscellaneous metal parts and products surface coating processes as specified in § 129.52, Table I, Category 10.

(4) [NA – NO VEHICLE COATING]

(5) [NA – LISTED EXEMPTIONS DO NOT APPLY]

(b) Definitions. [INCORPORATED BY REFERENCE]

(c) [NA – NO EXISTING RACT PERMIT]

(d) Emission limitations. Beginning January 1, 2017, a person subject to subsection (a)(1) may not cause or permit the emission into the outdoor atmosphere of VOCs from a miscellaneous metal part coating unit or miscellaneous plastic part coating unit, or both, unless emissions of VOCs are controlled in accordance with paragraph (1), (2) or (3).

(1) Compliant materials option. The VOC content of each miscellaneous metal part coating or each miscellaneous plastic part coating, as applied, excluding water and exempt compounds, is equal to or less than the VOC content limit for the applicable coating category specified in the applicable table of VOC content limits in Tables I—V.

(2)-(3) [NA – NO VOC CONTROL DEVICE]

(4) Least restrictive VOC limit. If more than one VOC content limit or VOC emission rate limit applies to a specific coating, then the least restrictive VOC content limit or VOC emission rate limit applies.

(5) Coatings not listed in Table I, II, VI or VII. For a miscellaneous metal part or miscellaneous plastic part coating that does not meet the coating categories listed in Table I, II, VI or VII, the VOC content limit or VOC emission rate limit shall be determined by classifying the coating as a general one component coating or general multicomponent coating. The corresponding general one component coating or general multicomponent coating limit applies.

(6) Coatings not listed in Table IV or IX. [NA – FACILITY DOES NOT USE PLEASURE CRAFT COATINGS]

(e) Compliance and monitoring requirements.

(1) All owners and operators. Regardless of the facility's VOC emissions, the owner or operator of a miscellaneous metal part surface coating process or miscellaneous plastic part surface coating process, or both, subject to subsection (a)(1) or

**SECTION E. Source Group Restrictions.**

(2), shall comply with this section as specified throughout this section. For an owner or operator subject only to subsection (a)(2), the compliance requirements are the recordkeeping requirements in subsection (f)(2).

(2) [NA – NO VOC CONTROL DEVICE]

(f) Recordkeeping and reporting requirements.

(1) The owner or operator of a miscellaneous metal part coating unit or miscellaneous plastic part coating unit, or both, subject to subsection (a)(1) shall maintain monthly records sufficient to demonstrate compliance with this section. The records must include the following information:

(i) The following parameters for each coating, thinner, component and cleaning solvent as supplied:

(A) Name and identification number of the coating, thinner, other component or cleaning solvent.

(B) Volume used.

(C) Mix ratio.

(D) Density or specific gravity.

(E) Weight percent of total volatiles, water, solids and exempt solvents.

(F) Volume percent of total volatiles, water and exempt solvents for the applicable table of limits in Tables I—V.

(G) Volume percent of solids for the applicable table of limits in Tables VI—IX.

(ii) The VOC content of each coating, thinner, other component and cleaning solvent as supplied.

(iii) The VOC content of each as applied coating or cleaning solvent.

(iv) The calculations performed for each applicable requirement under subsections (d) and (e).

(v) The information required in a plan approval issued under subsection (e)(2).

(2) [NA - FACILITY EMITS > 2.7 TPY VOC]

(3) The records shall be maintained onsite for 2 years, unless a longer period is required by an order, plan approval or operating permit issued under Chapter 127 (relating to construction, modification, reactivation and operation of sources).

(4) The records shall be submitted to the Department in an acceptable format upon receipt of a written request from the Department.

(g) Coating application methods. A person subject to subsection (a)(1) may not cause or permit the emission into the outdoor atmosphere of VOCs from a miscellaneous metal part coating unit or miscellaneous plastic part coating unit, or both, unless the coatings are applied using one or more of the following coating application methods:

(1) Electrostatic coating.

(2) Flow coating.

(3) Dip coating, including electrodeposition.

(4) Roll coating.

(5) High volume-low pressure (HVLP) spray coating.

**SECTION E. Source Group Restrictions.**

- (6) Airless spray coating.
- (7) Air-assisted airless spray coating.
- (8) Other coating application method if approved in writing by the Department prior to use.
 - (i) The coating application method must be capable of achieving a transfer efficiency equivalent to or better than that achieved by HVLP spray coating.
 - (ii) The owner or operator shall submit the request for approval to the Department in writing.
- (h) Exempt coatings and exempt coating unit operations.
 - (1) The requirements of subsections (d) and (g) do not apply to the application of the following coatings to a metal part:
 - (i) Stencil coating.
 - (ii) Safety-indicating coating.
 - (iii) Solid-film lubricant.
 - (iv) Electric-insulating and thermal-conducting coating.
 - (v) Magnetic data storage disk coating.
 - (vi) Plastic extruded onto metal parts to form a coating.
 - (vii) Powder coating.
 - (2) [NA – NO PLASTIC PARTS COATING]
 - (3) [NA - NO AUTOMOTIVE-TRANSPORTATION AND BUSINESS MACHINE PARTS COATING]
 - (4) The requirements of subsection (g) do not apply to the following activities:
 - (i) Application of a touch-up coating, repair coating or textured finish to a metal part.
 - (ii) [NA – NO PLASTIC PARTS COATING]
 - (iii) Airbrush application of coating to a metal part or plastic part using no more than 5 gallons of coating per year.
 - (iv) [NA – NO VOC CONTROL DEVICE]
 - (v) [NA – FACILITY DOES NOT USE PLEASURE CRAFT COATINGS]
 - (i) Work practice requirements for coating-related activities. The owner or operator of a miscellaneous metal part coating unit or miscellaneous plastic part coating unit, or both, subject to subsection (a)(1) shall comply with the following work practices for coating-related activities:
 - (1) Store all VOC-containing coatings, thinners or coating-related waste materials in closed containers.
 - (2) Ensure that mixing and storage containers used for VOC-containing coatings, thinners or coating-related waste materials are kept closed at all times, except when depositing or removing these coatings, thinners or waste materials.
 - (3) Minimize spills of VOC-containing coatings, thinners or coating-related waste materials and clean up spills immediately.
 - (4) Convey VOC-containing coatings, thinners or coating-related waste materials from one location to another in closed

**SECTION E. Source Group Restrictions.**

containers or pipes.

(j) Work practice requirements for cleaning materials. The owner or operator of a miscellaneous metal part coating unit or miscellaneous plastic part coating unit subject to subsection (a)(1) shall comply with the following work practices for cleaning materials:

- (1) Store all VOC-containing cleaning materials and used shop towels in closed containers.
- (2) Ensure that mixing vessels and storage containers used for VOC-containing cleaning materials are kept closed at all times except when depositing or removing these materials.
- (3) Minimize spills of VOC-containing cleaning materials and clean up spills immediately.
- (4) Convey VOC-containing cleaning materials from one location to another in closed containers or pipes.
- (5) Minimize VOC emissions from cleaning of application, storage, mixing or conveying equipment by ensuring that equipment cleaning is performed without atomizing the cleaning solvent and all spent solvent is captured in closed containers.

(k) Measurements and calculations. To determine the properties of a coating or component used in a miscellaneous metal parts surface coating process or miscellaneous plastic parts surface coating process, measurements and calculations shall be performed according to one or more of the following:

- (1) EPA Reference Method 24, Determination of Volatile Matter Content, Water Content, Density, Volume Solids, and Weight Solids of Surface Coatings, found at 40 CFR Part 60, Subpart D, Appendix A, including updates and revisions.
- (2) Manufacturer's formulation data.
- (3) Sampling and testing done in accordance with the procedures and test methods specified in Chapter 139.
- (4) Other test method demonstrated to provide results that are acceptable for purposes of determining compliance with this section if prior approval is obtained in writing from the Department.
- (5) [NA – NO VOC CONTROL DEVICE]
- (6) EPA calculations information in the following:
 - (i) A Guideline for Surface Coating Calculations, EPA-340/1-86-016, including updates and revisions.
 - (ii) Procedures for Certifying Quantity of Volatile Organic Compounds Emitted by Paint, Ink, and Other Coatings, EPA-450/3-84-019, including updates and revisions.

Table I. VOC Content Limits for Metal Parts and Products Surface Coatings
Weight of VOC per Volume of Coating, Less Water and Exempt Compounds, as Applied

General One-component - Air Dried: kg VOC/l coating; lb VOC/gal coating: 0.34;2.8
 General Multicomponent - Air Dried: kg VOC/l coating; lb VOC/gal coating: 0.34;2.8
 Extreme High-gloss - Air Dried: kg VOC/l coating; lb VOC/gal coating: 0.42;3.5
 Extreme Performance - Air Dried: kg VOC/l coating; lb VOC/gal coating: 0.42;3.5
 Metallic - Air Dried: kg VOC/l coating; lb VOC/gal coating: 0.42;3.5
 Pretreatment - Air Dried: kg VOC/l coating; lb VOC/gal coating: 0.42;3.5
 Touch-up and Repair - Air Dried: kg VOC/l coating; lb VOC/gal coating: 0.42;3.5

General One-component - Baked: kg VOC/l coating; lb VOC/gal coating: 0.28;2.3
 General Multicomponent - Baked: kg VOC/l coating; lb VOC/gal coating: 0.28;2.3
 Extreme High-gloss - Baked: kg VOC/l coating; lb VOC/gal coating: 0.36;3.0
 Extreme Performance - Baked: kg VOC/l coating; lb VOC/gal coating: 0.36;3.0

**SECTION E. Source Group Restrictions.**

Metallic - Baked: kg VOC/l coating; lb VOC/gal coating: 0.42;3.5
 Pretreatment - Baked: kg VOC/l coating; lb VOC/gal coating: 0.42;3.5
 Touch-up and Repair - Baked: kg VOC/l coating; lb VOC/gal coating: 0.36;3.0

Table II. [NA – NO PLASTIC PARTS SURFACE COATING]

Table III. [NA - NO AUTOMOTIVE-TRANSPORTATION AND BUSINESS MACHINE PARTS COATING]

Table IV. [NA – FACILITY DOES NOT USE PLEASURE CRAFT COATINGS]

Table V. [NA – NO MOTOR VEHICLE MATERIALS SURFACE COATINGS]

Tables VI – IX [NA FOR COMPLIANT MATERIALS OPTION]

II. TESTING REQUIREMENTS.

No additional testing requirements exist except as provided in other sections of this permit including Section B (Title V General Requirements).

III. MONITORING REQUIREMENTS.

No additional monitoring requirements exist except as provided in other sections of this permit including Section B (Title V General Requirements).

IV. RECORDKEEPING REQUIREMENTS.

No additional record keeping requirements exist except as provided in other sections of this permit including Section B (Title V General Requirements).

V. REPORTING REQUIREMENTS.

No additional reporting requirements exist except as provided in other sections of this permit including Section B (Title V General Requirements).

VI. WORK PRACTICE REQUIREMENTS.

No additional work practice requirements exist except as provided in other sections of this permit including Section B (Title V General Requirements).

VII. ADDITIONAL REQUIREMENTS.

No additional requirements exist except as provided in other sections of this permit including Section B (Title V General Requirements).

***** Permit Shield in Effect. *****

**SECTION E. Source Group Restrictions.**

Group Name: GROUP 006

Group Description: VOC Calculation Methods

Sources included in this group

ID	Name
199	ANNEALING
200	SHELL CORE
201	COREMAKING
203	COLDBOX COREMAKING
501	DISA POURING/CASTING
503	DISA CASTING/SHAKEOUT
601	SAVELLI POURING/CASTING
603	SAVELLI CASTING/SHAKEOUT

I. RESTRICTIONS.

No additional requirements exist except as provided in other sections of this permit including Section B (Title V General Requirements).

II. TESTING REQUIREMENTS.

No additional testing requirements exist except as provided in other sections of this permit including Section B (Title V General Requirements).

III. MONITORING REQUIREMENTS.

No additional monitoring requirements exist except as provided in other sections of this permit including Section B (Title V General Requirements).

IV. RECORDKEEPING REQUIREMENTS.

No additional record keeping requirements exist except as provided in other sections of this permit including Section B (Title V General Requirements).

V. REPORTING REQUIREMENTS.

No additional reporting requirements exist except as provided in other sections of this permit including Section B (Title V General Requirements).

VI. WORK PRACTICE REQUIREMENTS.

No additional work practice requirements exist except as provided in other sections of this permit including Section B (Title V General Requirements).

VII. ADDITIONAL REQUIREMENTS.**# 001 [25 Pa. Code §127.441]****Operating permit terms and conditions.****I. Emissions Calculation**

a.) Anvil shall calculate emissions using the following equations.

i. VOC emissions, ID 199 = (0.1 lb VOC/ ton metal) x (the actual monthly amount of material processed in tons) / (2,000 lbs./ ton)

ii. VOC emissions, ID 200 = (2.67 lb VOC/ ton sand) x (the actual monthly amount of material processed in tons) / (2,000 lbs./ ton)

iii. VOC emissions, ID 201 = (1.39 lb VOC/ ton sand) x (the actual monthly amount of material processed in tons) / (2,000 lbs./ ton)

**SECTION E. Source Group Restrictions.**

iv. VOC emissions, ID 203 = ((monthly resin usage x 0.082 lb VOC/ lb resin) + (monthly catalyst (DMPA) usage x scrubber reduction efficiency)) / (2,000 lbs./ ton). Scrubber efficiency is 98%.

v. VOC emissions, ID 501, 601 = (0.625 lb VOC/ ton metal) x (the actual monthly amount of material processed in tons) / (2,000 lbs./ ton)

vi. VOC emissions, ID 503, 603 = (0.178 lb VOC/ ton metal) x (the actual monthly amount of material processed in tons) / (2,000 lbs./ ton)

b.) Should the permittee choose to change any part of the production process which would affect emissions, Anvil will notify the Department of this change within 30 days and will provide the Department with an updated equation to calculate emissions when they notify the Department of the change.

***** Permit Shield in Effect. *****

**SECTION E. Source Group Restrictions.**

Group Name: GROUP 007

Group Description: RACT I Requirements

Sources included in this group

ID	Name
196	WASHERS
501	DISA POURING/CASTING
502	DISA CASTING/COOLING
503	DISA CASTING/SHAKEOUT

I. RESTRICTIONS.

No additional requirements exist except as provided in other sections of this permit including Section B (Title V General Requirements).

II. TESTING REQUIREMENTS.

No additional testing requirements exist except as provided in other sections of this permit including Section B (Title V General Requirements).

III. MONITORING REQUIREMENTS.

No additional monitoring requirements exist except as provided in other sections of this permit including Section B (Title V General Requirements).

IV. RECORDKEEPING REQUIREMENTS.

No additional record keeping requirements exist except as provided in other sections of this permit including Section B (Title V General Requirements).

V. REPORTING REQUIREMENTS.

No additional reporting requirements exist except as provided in other sections of this permit including Section B (Title V General Requirements).

VI. WORK PRACTICE REQUIREMENTS.

No additional work practice requirements exist except as provided in other sections of this permit including Section B (Title V General Requirements).

VII. ADDITIONAL REQUIREMENTS.**# 001 [25 Pa. Code §129.91]****Control of major sources of NOx and VOCs**

Anvil International, LLC, Columbia Borough, Lancaster County
RACT Operating Permit No. 36-2019 SIP requirements

VOC emitting foundry operations include the following:

Source: Manufacturer

(A) North Foundry [ALL NORTH FOUNDRY SOURCES DECOMMISSIONED]

Pouring/Castings: Jeffrey

Castings Cooling: Jeffrey

Casting Shakeout: Didion/GK

(B) South foundry

Mini-In-Line Castings Shakeout: Didion/GK [DECOMMISSIONED]

Mini Pouring/Castings: Sand Mold Systems, Inc. [DECOMMISSIONED]

Mini Castings Cooling: Sand Mold Systems, Inc. [DECOMMISSIONED]

Castings Cooling, Disa.: Disamatic, Inc. [SOURCE 503]

Casting Shakeout, Disa.: Didion/GK [SOURCE 502]

**SECTION E. Source Group Restrictions.**

Casting Shakeout, Disa.: Didion/GK [SOURCE 502]
Casting Shakeout, Disa.: Didion/GK [SOURCE 502]
Pouring Castings, Disa.: Sand Mold Systems, Selcom [SOURCE 501]

(C) Four Washers - Rust Inhibitors: Anvil International [SOURCE 196]

1. The source and any associated air cleaning devices are to be:

- a. operated in such a manner as not to cause air pollution;
- b. in compliance with the specifications and conditions of the Reasonably Available Control Technology (RACT) plan;
- c. operated and maintained in a manner consistent with good operating and maintenance practices.

4. This permit constitutes a RACT determination as per 25 Pa. Code Sections 129.91 and 129.92 for VOC emitting foundry operations except degreasers and paint line.

5. Manufacturer supplied VOC Data Sheets or Material Safety Data Sheets for all binders and coatings used at this facility within the most recent two years shall be maintained at the above location and be made available to the Department at any time.

6. The potential to emit VOC emissions generated from the foundry operations including clean-up (except degreasers and paint line) covered under Permit No. 36-2019 shall never exceed 208 tons per calendar year. The calendar year is from 12:00 a.m. January 1 through 11:59 p.m. December 31.

7. Anvil International shall develop a VOC accounting form to record quantity and type of solvent/binder used, quantity of spent organic solvent generated, disposed off-site, and recycled on-site etc. This form must be submitted to the Department t prior to April 30, 1995 for approval.

8. Annual reports including various binders/solvents used in different foundry operations including VOCs in binders/solvents, consumption of binders/solvents, pounds per year of VOC emissions, and total hours per year operation shall be submitted to the Lancaster District Supervisor. Each report (January 1 through December 31) is due no later than March 1 of the following year for each operating year authorized by the permit or its renewal. Also, the report must contain monthly usage of binders/solvents and its VOC emissions.

***** Permit Shield in Effect. *****

**SECTION E. Source Group Restrictions.**

Group Name: GROUP 008

Group Description: 129.99 CbC RACT II

Sources included in this group

ID	Name
199	ANNEALING
200	SHELL CORE
201	COREMAKING
203	COLDBOX COREMAKING
501	DISA POURING/CASTING
503	DISA CASTING/SHAKEOUT
601	SAVELLI POURING/CASTING
603	SAVELLI CASTING/SHAKEOUT

I. RESTRICTIONS.

No additional requirements exist except as provided in other sections of this permit including Section B (Title V General Requirements).

II. TESTING REQUIREMENTS.

No additional testing requirements exist except as provided in other sections of this permit including Section B (Title V General Requirements).

III. MONITORING REQUIREMENTS.

No additional monitoring requirements exist except as provided in other sections of this permit including Section B (Title V General Requirements).

IV. RECORDKEEPING REQUIREMENTS.

No additional record keeping requirements exist except as provided in other sections of this permit including Section B (Title V General Requirements).

V. REPORTING REQUIREMENTS.

No additional reporting requirements exist except as provided in other sections of this permit including Section B (Title V General Requirements).

VI. WORK PRACTICE REQUIREMENTS.

No additional work practice requirements exist except as provided in other sections of this permit including Section B (Title V General Requirements).

VII. ADDITIONAL REQUIREMENTS.**# 001 [25 Pa. Code §129.99]****Alternative RACT proposal and petition for alternative compliance schedule.**

I. Requirements for all sources under this group

a.) The facility shall operate and maintain the pouring casting/cooling, annealing, shell core machines, coremaking, cold box coremaking, and shakeout operations in a manner consistent with good operating and maintenance practices. Good work practices include but are not limited to storing VOC-containing materials in closed tanks or containers, cleaning up spills, and minimizing cleaning with VOC compounds.

b.) The permittee shall demonstrate the VOC content of each binder and chemical used in the foundry operation by maintaining VOC data sheets from the manufacturer.

c.) The permittee shall maintain monthly records of the following. These records shall be maintained onsite for 5 years and shall be made available to the Department upon request.

**SECTION E. Source Group Restrictions.**

- i. The monthly amount of material processed in each source in tons, separately.
 - ii. The monthly emissions of VOC emissions, in tons, for each source, separately and combined.
- d.) The permittee shall submit reports to the Department no later than March 1 of each year. Each report shall include the VOC emissions for the previous operating year (January 1 to December 31).
- II. Additional requirements for source 203
- a.) The permittee shall utilize the existing wet acid scrubber for controlling VOC emissions.
 - b.) The scrubber shall be in operation at all times when one or more of the coldbox coremaking machines are in operation.
 - c.) The permittee shall continuously measure and display the pressure drop across the scrubber, the scrubbing pH and the scrubber solution recirculation flow rate.
 - d.) The permittee shall maintain records of all maintenance performed on the scrubber. These records shall be kept at the facility for a period of 5 years and be made available to the Department upon request.
 - e.) The permittee shall record the following parameters once per week while the coldbox coremaking machine(s) are in operation: the pressure drop across the scrubber, the scrubbing pH and the scrubber solution recirculation flow rate. The permittee shall maintain these records for a period of 5 years and be made available to the Department upon request.
- III. Source Specific Throughput Restrictions
- a.) The resin coated sand consumption from source 200, the shell core operation, shall not exceed 1,950 tons per 1 month period.
 - b.) The resin coated sand consumption from source 201, coremaking, shall not exceed 1,500 tons per 1 month period.
 - c.) The metal throughput to source 199, annealing operations, shall not exceed 7,000 tons per 1 month period.
 - d.) The throughput to sources 501, 503, 601, 603, foundry operations, shall not exceed 20,500 tons of metal per 1 month period.
 - e.) The resin consumption from source 203, coldbox coremaking operations, shall not exceed 7.6 tons per 1 month period.

*** **Permit Shield in Effect.** ***



SECTION F. Alternative Operation Requirements.

No Alternative Operations exist for this Title V facility.



SECTION G. Emission Restriction Summary.

No emission restrictions listed in this section of the permit.

**SECTION H. Miscellaneous.**

This permit renewal incorporates requirements from operating permit 36-05019 issued on 2/18/2009 and supercedes that permit.

The following activities do not required any emission restrictions, testing, monitoring requirements and reporting requirements, and work practice standards:

- (1) Galvanizing Pickling Line
- (1) Galvanizing shotblast controlled by DC-460 (vented indoors)
- (1) Galvanizing shotblast controlled by DC-461 (vented indoors)
- (3) Shotblast machines controlled by DC-462 (vented indoors)
- (1) Shotblast machine controlled by DC-463 (vented indoors)
- (1) Coldbox coremaking sand transporter system
- (1) Source ID #191 - Thermal Deposition Coating System (waterbased polymer solution)

Source ID #188 - Melt Operations- consists of the following:

- (3) Electric induction melting furnaces.
- (3) Electric Induction holding furnaces.

Existing Source ID #503 - Disa Casting Shakeout - has been modified to include the following additional components:

- (1) Disa #2 to Didion No. 1 Conveyor (Unit #507) - 60 tph
- (1) Disa #3 to Didion No. 2 Conveyor (Unit #519) - 60 tph
- (1) Disa #4 to Didion No. 3 (Unit #607) - 60 tph

Existing Source ID #504 - Disamatic Sand System - has been modified to include the following additional components:

- (3) Spill Sand Conveyors (Units #231 thru #233) - 60 tph ea.
- (1) Spill Sand Collecting Conveyor (Unit #234) - 60 tph
- (1) Prepared Sand Aerator (Unit #252) - 200 tph
- (1) Prepared Sand Transfer Plow (Unit #250) - 200 tph
- (1) Prepared Sand Transfer Belt Conveyor (Unit #251) - 200 tph
- (1) Prepared Sand Hopper (Unit #253) - 15 tph
- (1) Cope Molding Machine Belt Feeder (Unit #254) - 100 tph
- (1) Drag Molding Machine Belt Feeder (Unit #255) - 100 tph
- (1) Water Addition (Unit #533) - 33 gal/min
- (1) Didion Sand Discharge Conveyor (Unit #242) - 60 tph

New Source ID #601 - Savelli Pouring/Casting - consists of the following components:

- (1) Junker Pouring Furnace (Unit #260) - 10 tph
- (1) Mold Pouring Zone (Unit #211) - 260 molds/hr

New Source ID #602 - Savelli Casting/Cooling - consists of the following components:

- (1) Mold Cooling Enclosure (Unit #211) - 260 molds/hr

New Source ID #603 - Savelli Casting/Shakeout

- (2) Casting Vibratory Conveyors (Unit 27D & 28) - 20 tph ea.
- (2) Casting Transfer Conveyors (Unit 243 & 244) - 20 tph ea.
- (1) Disamatic #2 Casting Transfer Unit (Unit #240) - 10 tph
- (1) Didion Drum (Unit #241) - 80 tph
- (1) Mold Dump Conveyor (Unit #237) - 70 tph
- (1) Mold Transfer Conveyor (Unit #238) - 70 tph
- (1) Didion Feed Conveyor (Unit #239) - 80 tph
- (1) Mold Punch-Up/Push-Off (Unit #215) - 260 molds/hr

The facility had the following approved request for determination (RFD) since the last permit renewal which occurred on 7/21/2014:

RFD 1402 (not eRFD); approved 7/19/16, for replacement-in-kind of fabric filters Wheelabrator #425 (C04) and Wheelabrator #426

**SECTION H. Miscellaneous.**

(C06) with identical fabric filters ETA #425 and ETA#426, due to the existing controls having come to the end of their service life. The replacement units are to be manufactured by ETA as duplicate units including filter bags, inlet/outlet, etc., with no changes made to sources or ductwork

RFD 1497 (eRFD 6008); approved 12/8/16, for replacement of the heated pressure-pour vessel on Disa #4 (a component of source 501) with an unheated pouring vessel. No changes are to be made to raw materials, hours of operation, throughputs nor actual or potential emissions.

RFD 1836 (eRFD 6997); approved 5/11/18, to add four (4) Desma Model D-968.400 injection rubber molding machines. The proposed addition is estimated to result in an increase in VOC emissions of 0.22 tons/year and HAP emissions of 0.14 tons/year.

RFD 1837 (eRFD 7008); approved 5/11/18, to add one (1) new Gaylord Model SATB-15 coldbox core machine to the existing coldbox coremaking operations (Source 203) and decommission an existing ABC core machine (currently permitted under Source 201). The proposed change is estimated to result in an actual VOC emissions increase of 0.07 tons per year.

RFD 1873 (eRFD 7178); approved 9/5/18 to replace one (1) fabric filter control device with a nearly identical "replacement in kind" unit, due to the current control unit nearing the end of its service life. The existing control is identified in the existing T5 permit as C07 (Wheelabrator #414) under Source 505 (Grinding) and Source 305 (N.F. Cleaning). All emissions were asserted to remain unchanged as a result of the replacement.



***** End of Report *****
